

Here's what I've been able to put together from numerous posts 🙌, and my own (newbie) experience. I hope this helps others, as I couldn't have done any of this without this forum (many thanks to those who have contributed and shown the way - I have taken many liberties 😊 with other's photos in this post)...

Here we go:

Gently pull up the driver side center console upper trim to release the 9 retaining clips and 3 tabs, starting from the back. I agree with wrapping a butter knife with a cloth for added scratch resistance. Gently 'twist' the butter knife to release the retaining clips one by one, slowly moving to the front...

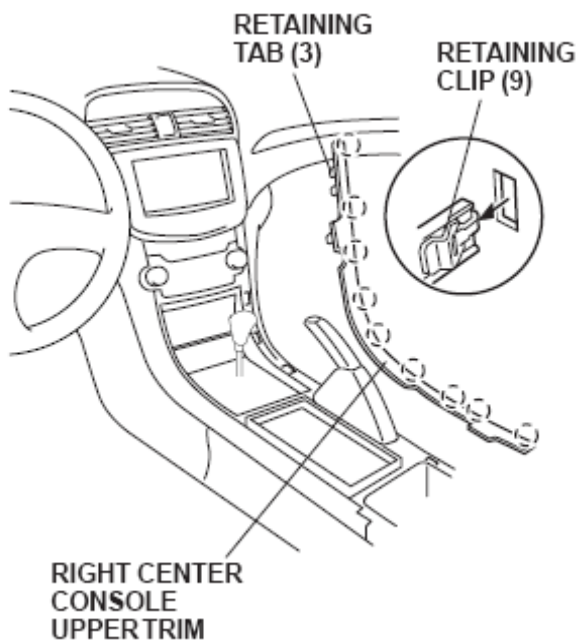

Open the console box, and remove the mat at the bottom to expose the two screws - and remove. This will provide 'play' in the console and will help with the removal of the side panel.



Remove self-tapping screws on driver side that were under removed trim.

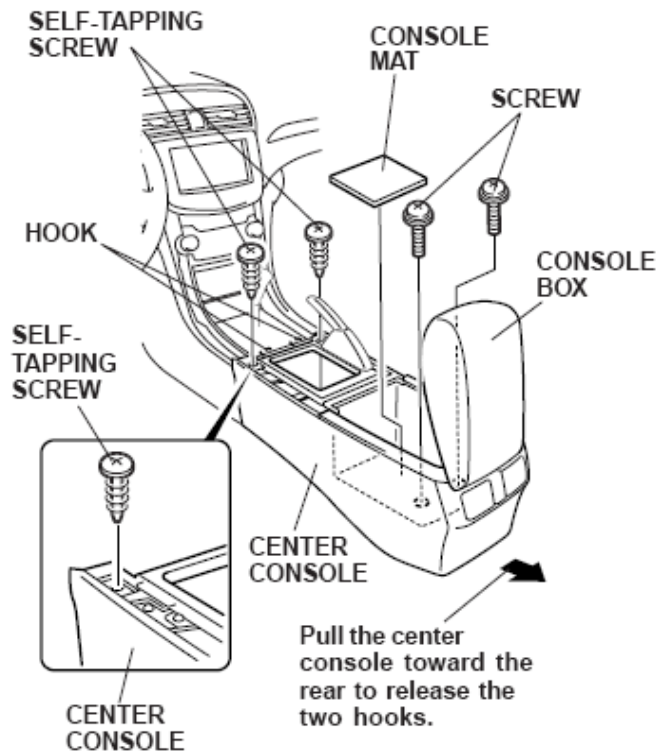

Remove the bottom left screw on this illustration (again exposed from removed trim) - Note you do not need to remove gear shift knob-....



Next is loosening the covering under the steering wheel. Unscrew the one screw located underneath and to the right of the panel. It is the only screw. You can then use the butter knife technique again to pry the panel away. It is held by clips that will pop off without too much pressure. You do not have to completely remove this, only enough to 'massage' the driver side center console cover off.



You don't have to move it out this far, but you can if you prefer (it just gets in the way if it is 'dangling').



There are two screws (self-tapping) behind the loosened cover that need to be removed to free up the driver's side center console cover.

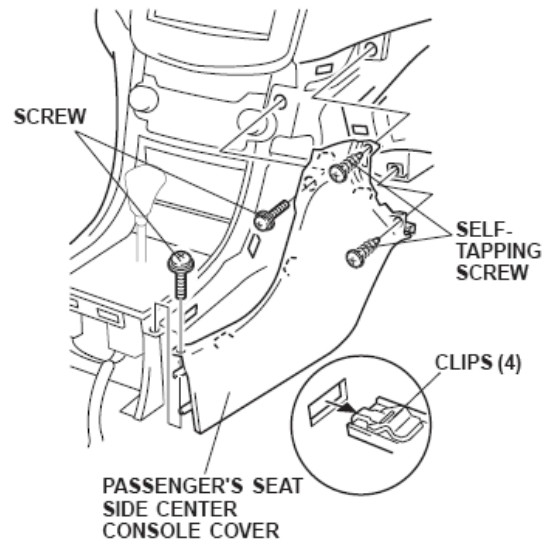
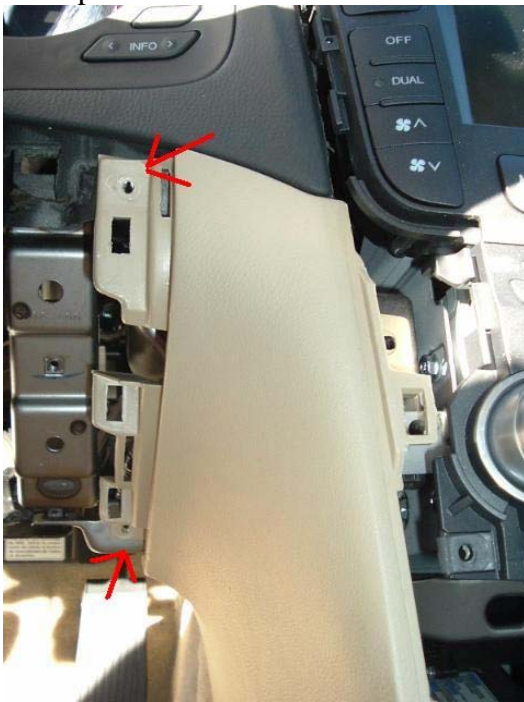

You then remove the cover (again the butter knife technique works well to remove the 4 retaining clips). Gently maneuver the cover out from behind the loosened steering wheel cover. There are two tabs that fit behind the other side cover of the center console that have to be maneuvered out - remember to use the 'play' in the center console.



Fold down the carpeting from the side console (there are a couple of clips easily removed) to gain access to the back of the unit with the aux input.

Here's where it gets 'comfy'. Move the driver's seat all the way back, recline the seat back fully and with your feet at the head rest and your head resting on the accelerator, with a flashlight by your head shining into the back of the head unit you are in position. If you have a TL with XM, you will have to move the 14pin plug - luckily I didn't have to do this). Once removed you have to insert the AUX connector into the open outlet. Others have used a coat hanger bent to fit inside the plug to facilitate pushing this into place, I simply used two hands

-the left from behind to push the connector in,

-the right through the side (small opening -enough for two fingers) to guide it in.

This step can take a few minutes (about 10 for me) but don't give up, take a break if you have to, once it is in - euphoria! 😊



Now you have to decide where to run the cable, and where to put the 'box'. I decided to run the cable behind the drivers side console cover, have the box under the driver's seat (relatively easy access), and the cable for my ipod and Sirius run from under the driver's seat under the console, through the door at the bottom of the console box (used wire cutters to snip the corner off of the door to fit the wires - some have drilled a hole, wire cutters are simpler 🐻🐻) and reinstall panels.

I love the set-up and want to spend even more time in my TL. Sound is tremendous vs. FM modulation (again my 🐻🐻)