

1967
FORD

PICKUPS

CONVENTIONAL F-100/F-250/F-350

Boy & Boot

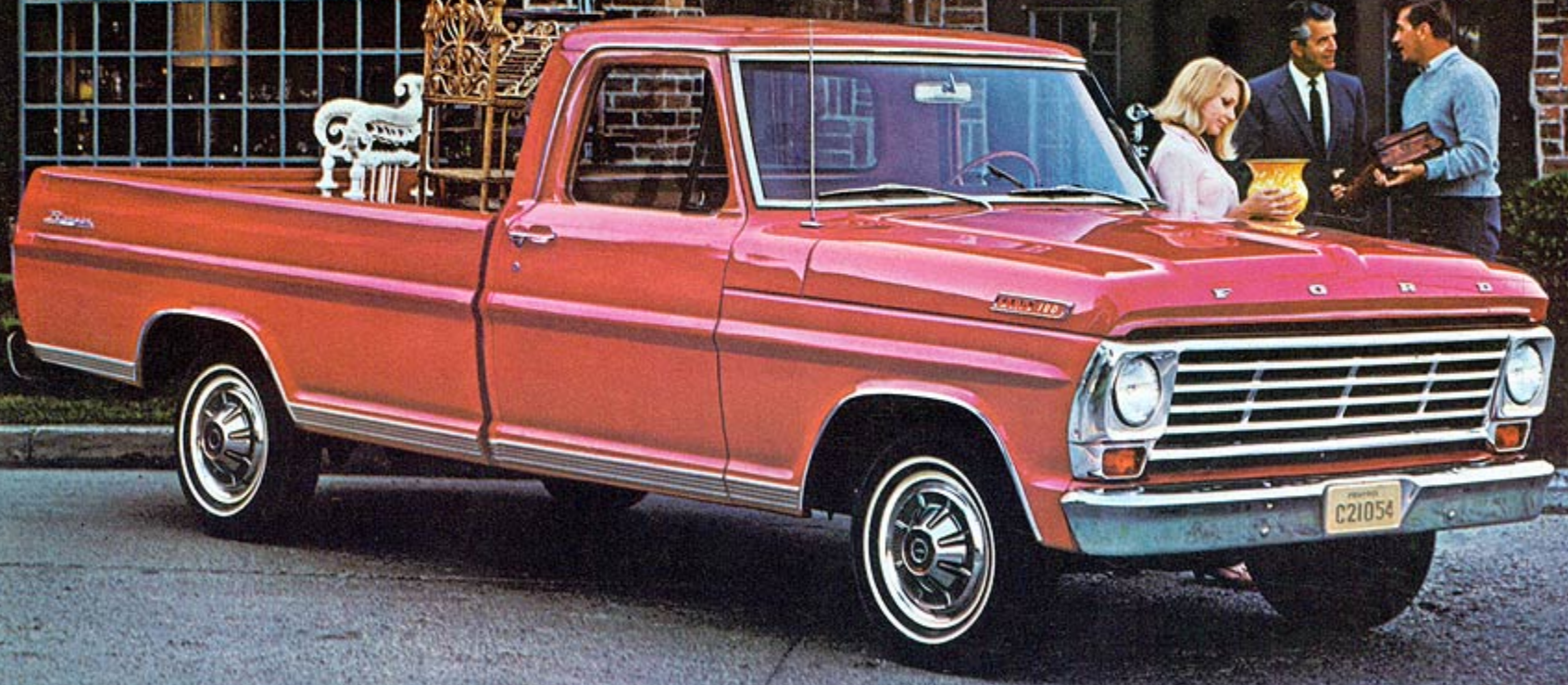

Three new Ford Pickups . . . work like trucks, ride like cars!

Ford's all-new 1967 pickups are tougher and smoother! Tougher from the frame up . . . and a pleasure to drive. Compare them with cars, not trucks, as to comfort, smoothness and quiet ride! The all-new styling is functional; cabs are roomier, visibility is better, too! In addition, new *double-wall* hood sections provide outstanding stability and rigidity. *Double-wall* side panels of Styleside pickup bodies protect outer walls. F-100/250 Series Stylesides bring you a new idea in pickups, the Ranger! F-100 Rangers have 115- and 131-inch wheelbases with 6½- and 8-ft. Styleside boxes

respectively. The F-250 Ranger has a 131-inch wheelbase and 8-ft. box. Both the F-100 and F-250 Series have Ford's road-smoothing Twin-I-Beam front suspension. And now for '67 so does the *F-350 Series!* The F-350 with new 135-inch wheelbase is available with 9-ft. Flare-side pickup, stake and platform bodies and as chassis-cab, cowl or windshield models. New 159-inch wheelbase F-350 are offered for commercial bodies up to 12-ft. long or 14-ft. chassis-mounted cab-over campers. And by special order, a 6-man crew cab is available for F-250 and 350 Series pickups and chassis-cab models.



Twin-I-Beam Front Suspension is one big reason why Ford pickups come so tough, ride so smoothly. Twin-I-Beam design has two front axles, one for each wheel. Wheels roll over bumps independently to smooth out the ride on any road. But don't let the smooth ride fool you: Twin-I-Beam front suspension is all truck. Each axle is a forged steel I-beam, like the axles on big trucks. And each axle is held in alignment by a forged steel radius rod. Quite a design . . . a design you won't find on any other pickup! First introduced in 1965 model F-100's and 250's, a new heavy-duty version is now standard on the F-350 Series.

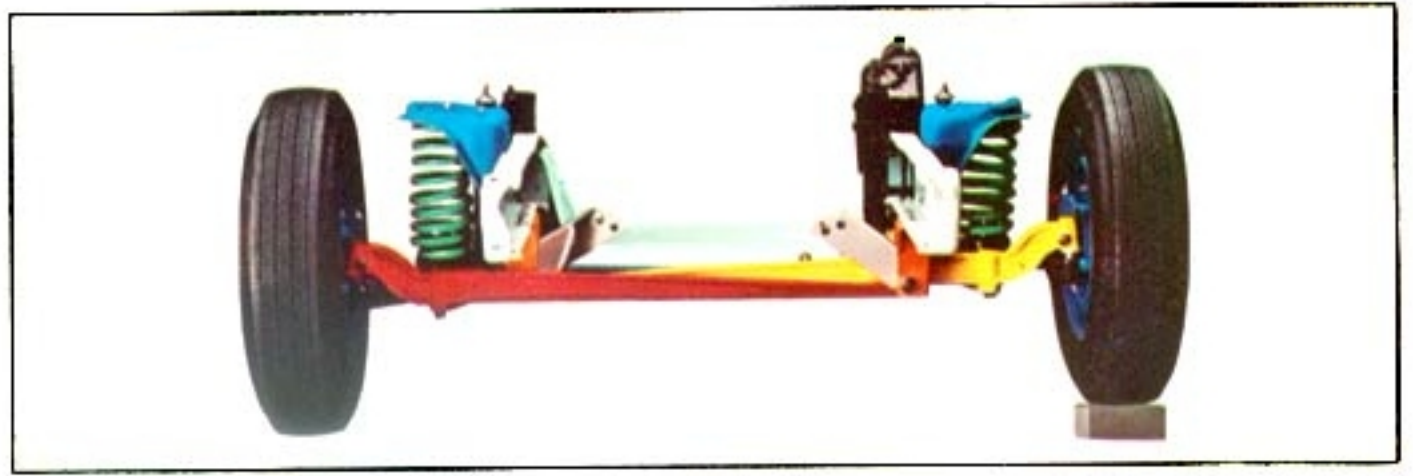

F-250 STYLESIDE 3 MAN CREW CAB



F-250 FLARESIDE PICKUP

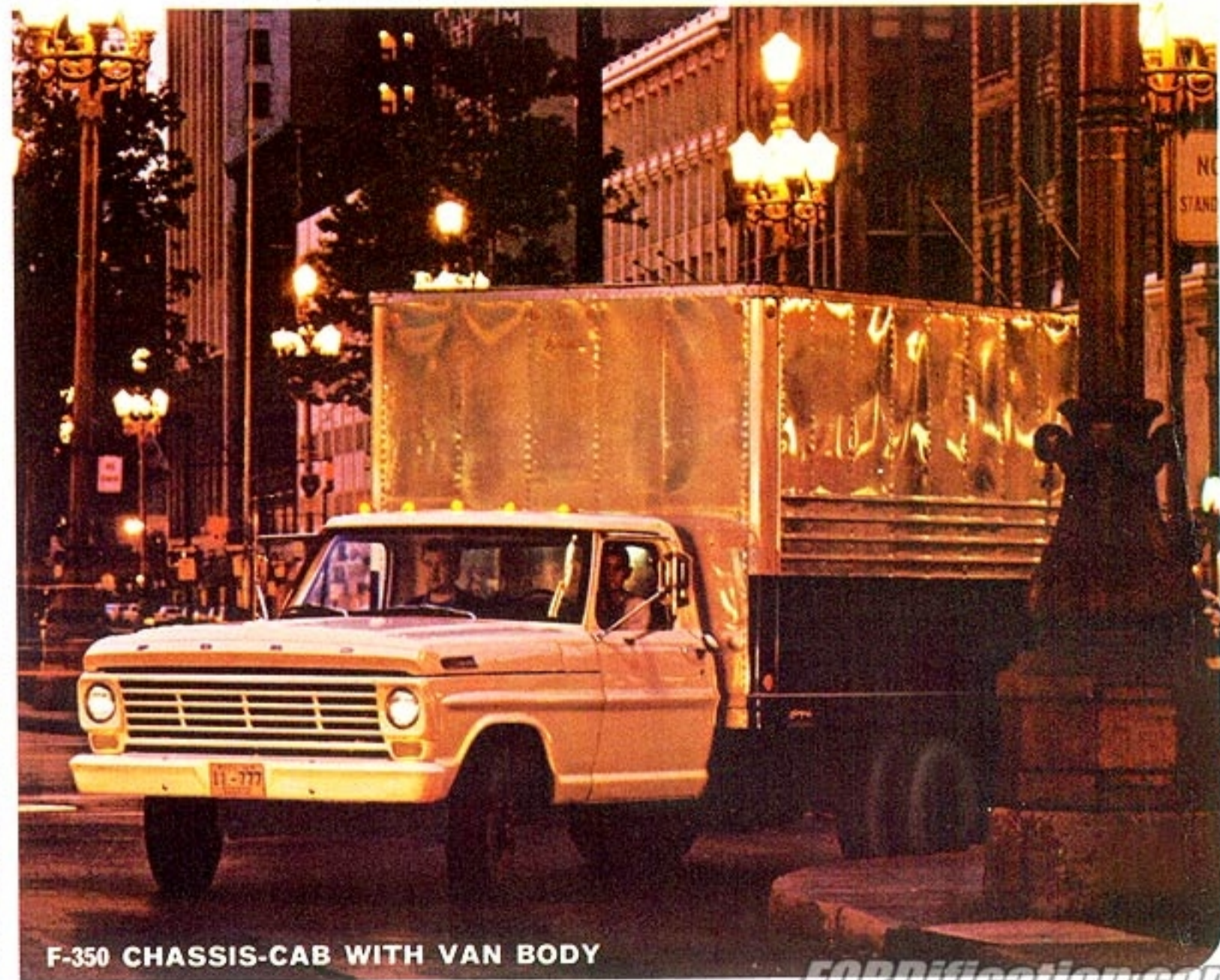

F-350 CHASSIS-CAB WITH VAN BODY

More attractive, more spacious cab interiors



Everything about Ford's new interiors says comfort, luxury and spaciousness—loud and clear! You have a choice of three cab interiors . . . standard cab, Custom Cab or the exclusive cab of the Ranger. All interiors are bigger . . . nearly four inches more shoulder room. Seats are three inches wider . . . deep-cushioned and more comfortable, too. A new swept-away instrument panel provides extra space. You can even insert the ignition key either side up—it's reversible. Ford pickups look more rugged, have more carlike-styled interiors, ride more like cars and still they are the toughest Ford pickups . . . ever!

RANGER—Ford's all-new, top-of-the-line F-100/250 Styleside pickup! The full-width, deep-cushioned seat is upholstered in a highly styled durable vinyl with a soft cloth appearance. Vinyl door trim panels and deep-pile carpeting are handsomely trimmed with bright-metal moldings. Upholstery is keyed to main body colors. The horn ring, instrument cluster, headlining and instrument padding moldings are bright-finished. Outside, bright-finished front bumper, grille, headlight assembly, hub caps and wheel lip, rocker panel and tailgate moldings add extra sparkle . . . clearly identifies Ranger as Ford's finest full-size pickup.



RANGER INTERIOR (F-100/250 STYLESIDE PICKUPS)

CUSTOM CAB is optional with all F-100/250/350 Series Fords. The all-new Custom Cab offers plenty of luxury and comfort! Woven-plastic seat trim in red, blue, green or beige is color-keyed to exterior paint; deep foam-cushioned, full-width seat can seat three big people comfortably; arm rests and rubber floor mat are also color-keyed to main body color; cigar-cigarette lighter; bright-finish horn ring, headlining retainer molding and instrument cluster further add to the cab's good-looking interior. Bright-metal grille, headlight assembly, taillight bezels, windshield reveal molding and "Custom Cab" plaques give the Custom Cab's exterior a distinctive appearance.

STANDARD CAB features include a padded instrument panel, color-keyed to exterior paint; attractive, functional instrument cluster; foot-operated parking brake; push-button latch on glove box door; aluminum door scuff plates; slide-action air vents for improved ventilation and easy operation; Deluxe fresh air heater and defroster; one-piece, easy-to-keep-clean hardboard headlining; and a full-width red, blue, green or beige vinyl-trimmed seat color-keyed to cab paint. Never before have Ford standard cabs been so attractive!

FORD MOTOR COMPANY LIFE-GUARD-DESIGN LIGHT TRUCK SAFETY FEATURES* are standard on all F-100/250/350 Series Fords and include dual hydraulic brake system with warning light, seat belts, padded instrument panel, safety door latches and safety hinges, outside mirror, windshield washers, two-speed windshield wipers, padded sun visors, thick laminate safety plate glass windshield, turn indicators, backup lights, ICC 4-way emergency flasher, front seat shoulder harness anchors, corrosion-resistant brake lines, safety-designed instrument panel and controls, uniform shift quadrant, reduced-glare instrument panel and wiper arms and blades.

**Slight variation on chassis-cowl and windshield models.*



CUSTOM CAB INTERIOR (F-100/250/350)



STANDARD CAB INTERIOR (F-100/250/350)

Convenience Options



Power Brake for more effortless stopping—need less pedal pressure, making driving easier. Available on all F-100/250/350 Series Fords.



Power Steering takes the work out of parking, turning, driving. You'll appreciate power steering on the job at day's end. Available on F-100 and F-250 Series.



SelectShift Cruise-O-Matic lets you drive fully automatic or shift manually through the gears. New "second hold" feature improves engine braking and power application on hills.



Bucket Seats (F-100/250/350 Series Fords) add sports flair, provide individual comfort. Foam-padded, vinyl-covered seats are color-keyed to exterior paint.

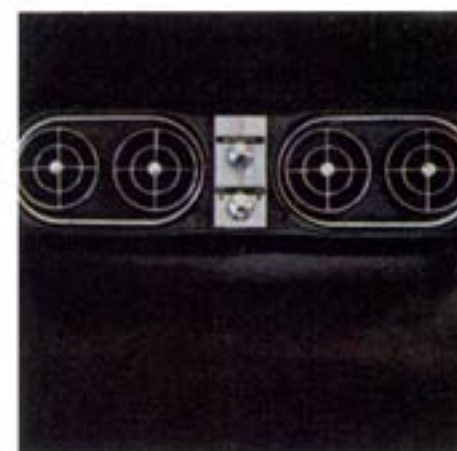

SelectAir Conditioner ends summer heat, noise, dirt, pollen and odors. This dealer-installed item cools cab and maintains a comfortable temperature.



Transistorized Radio gives you instant reception. Keeps you posted on traffic conditions, weather and news... helps ease long hours behind the wheel.

A wide choice of Fords to meet your needs...

STYLESIDE PICKUPS feature smooth styling with body side panels extended forward to hug the contour of rear cab corners. F-100 pickups come with 6½- and 8-ft. cargo boxes on 115- and 131-inch wheelbases respectively. F-250 pickups have 8-ft. boxes with 131-inch wheelbases. The Styleside pickup features *double-wall* cargo area side panels and tailgate with an all-steel floor for durability. A single, center latch opens and clicks-shut the tailgate quickly and easily . . . and only *one* hand does it!

FLARESIDE PICKUPS have the same cargo box lengths and wheelbases as Stylesides for both the F-100 and F-250 Series. The F-350 Flareside has a 9-ft. box with the new 135-inch wheelbase. Flareside features include running boards between cab and rear fenders for easier over-the-side loading; seasoned hardwood floorboards with steel skid strips to help slide cargo into place; rubber-covered, forged steel chains to support the tailgate, and steel side panels with rolled edges to provide extra strength and rigidity.

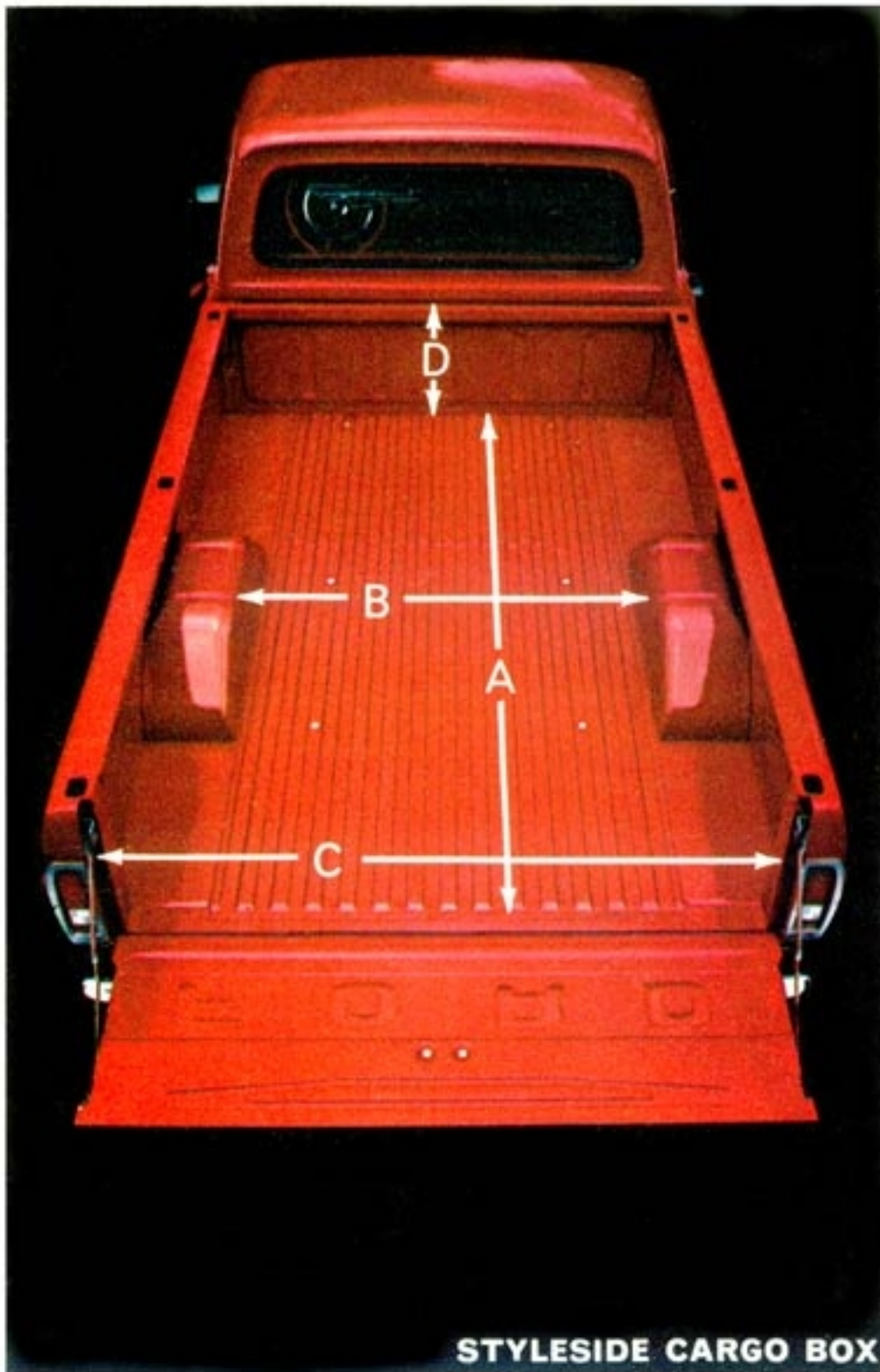

F-100/250/350 CARGO AREA DIMENSIONS (ABOVE)

MODELS	STYLESIDE			FLARESIDE				STAKE OR PLATFORM				
	F-100		F-250	F-100		F-250	F-350	F-100		F-250		F-350
WHEELBASE (in.)	115	131	131	115	131	131	135	115	131	135	159	
Nominal Cargo Box Length (ft.)	6½	8	8	6½	8	8	9	6½	7½	9	12	
Inside Length (in.) (A)	78.19	98.19	98.19	77.9	96.0	96.0	108.1	80.0† 84.3††	90.0† 93.4††	106.0† 109.4††	142.0† 145.4††	
Width Between Wheelhousings (in.) (B)	49.0	49.0	49.0	**	48.4	48.4	48.4	—	—	—	—	
Tailgate Opening (in.) (C)	65.0	65.0	65.0	49.0	54.0	54.0	54.0	67.0† 71.3††	73.7† 79.3††	82.1† 87.3††	82.1† 87.3††	
Floor to Top of Sides Height (in.) (D)	19.30	19.30	19.30	20.3	22.1	22.1	22.1	24.5	28.3	31.2	42.0	
Cargo Capacity (cu. ft.)	60.3*	76.4*	76.4*	45.0	65.4*	65.4*	74.0*	—	—	—	—	

*Allowance made for wheelhousings **No inside wheelhousings †Stake ††Platform

CHASSIS-CAB MODELS are designed to accommodate custom-built bodies. F-100 chassis-cabs can take bodies from 5½ to 8 ft. long; F-250's—from 6½ to 8 ft. long and F-350—from 9 to 12 ft. long. A 12-ft. cab-over chassis-mounted camper body can be installed on an F-350 Camper Special 135-inch wheelbase; 14-ft. chassis-mounted cab-over camper body can be mounted on an F-350 Camper Special with a 159-inch wheelbase and dual rear wheels. Your Ford Dealer will be glad to help you select the right body to meet your needs.

STAKE AND PLATFORM MODELS are designed to haul bulky and odd-shaped loads. Stake and platform models come in the following wheelbases and body lengths: F-100 with 115" wheelbase—6½-ft. body; F-250 with 131" wheelbase—7½-ft. body; F-350 with 135" wheelbase—9-ft. body; F-350 with 159" wheelbase—12-ft. body. Dual rear wheels are available with the F-350 for greater payload capacity. Seasoned hardwood floorboards are interlocked with steel skid strips. Floor corners are reinforced with steel angle brackets.

CHASSIS-COWL AND CHASSIS-WINDSHIELD MODELS are easily adapted to single-unit bodies of the walk-in type. F-100's have a 115-inch wheelbase; F-250 chassis have a 131-inch wheelbase; and F-350 chassis have 135- and 159-inch wheelbases. F-250/350 6-man crew cab pickup and chassis-cab models are available by special order. F-250's have a 149-inch wheelbase; F-350's have a 164.5-inch wheelbase. These Fords are ideally suited for field service operations and hauling camper coaches.

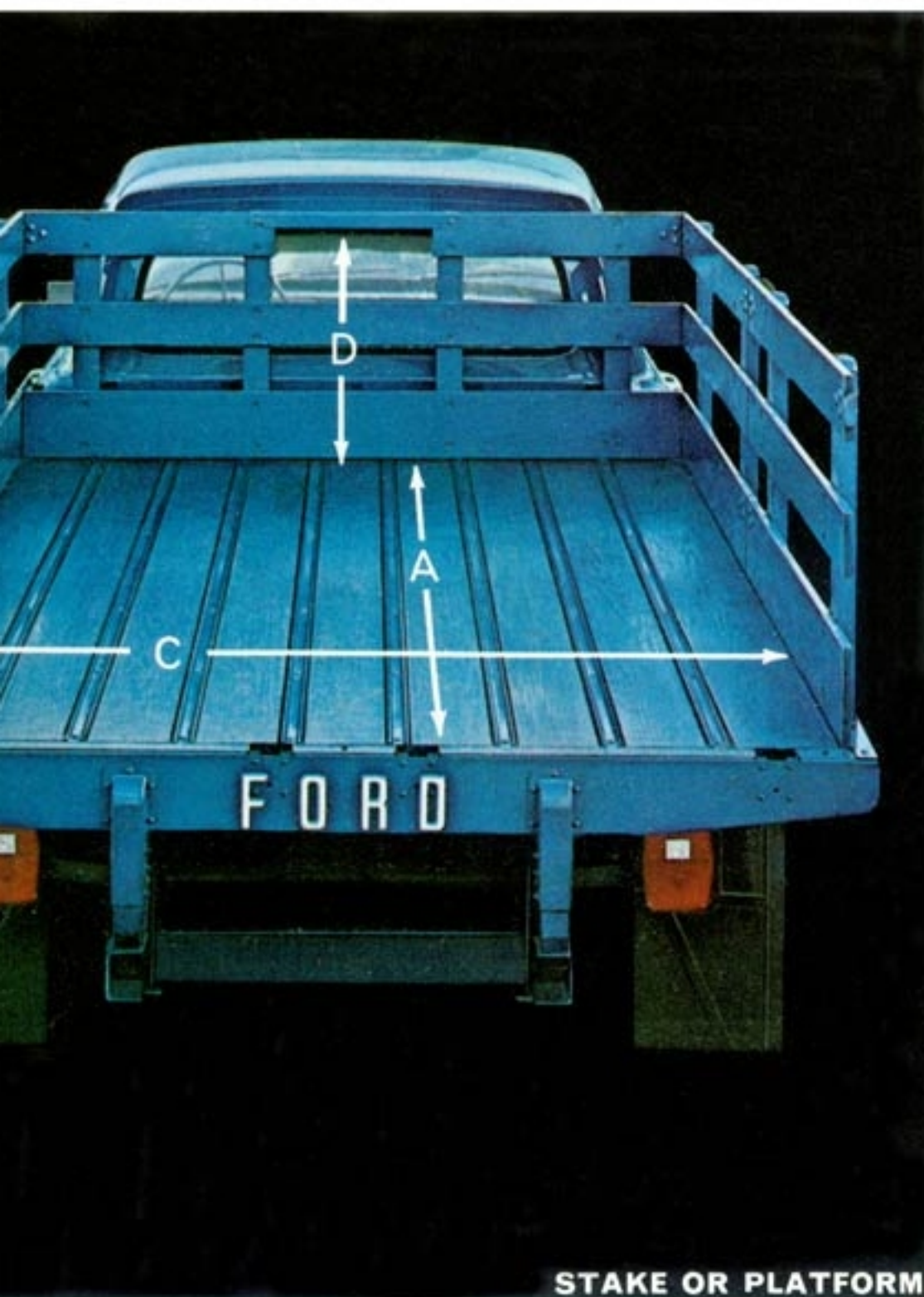

STAKE OR PLATFORM

Ford Truck Body Features



Double-Wall Hood sections provide increased hood rigidity. DOUBLE-WALL SIDE PANELS of Styleside pickups give extra strength and protect exterior sheetmetal against damage caused by shifting cargo.



One-Hand-Operated Hood Latch is standard to improve engine compartment accessibility. No groping with two hands . . . the new latch is easy to reach and open with just one hand!



One-Hand Tailgate Latch on Styleside pickups. Pull—tailgate opens to a horizontal position. Push—it snaps shut automatically. Center latch releases tailgate in one easy motion. Only one hand does it!



Flareside Running Board is a wide, ribbed steel step between the cab and rear fenders to permit easy loading from either side. Running board is standard equipment on F-100/250/350 Flareside pickups.

F-100/250/350 CHASSIS-CAB DIMENSIONS (RIGHT)

DIMENSIONS (in.)	F-100	F-250	F-350
Wheelbase (WB)	115	131	135
Front bumper to front axle (A)	30.7	30.7	30.7
Front bumper to back of cab (B)	105.7	105.7	105.7
Back of cab to rear axle (C)	40	56	60
Rear axle to end of frame (D)	36.8	40.6	38.5
Frame to cab roof ht. (E)	47.5	47.5	47.5
Frame to ground ht.—empty (F)	26.6	26.2	27.9
Overall length (G)	182.5	202.3	204.2

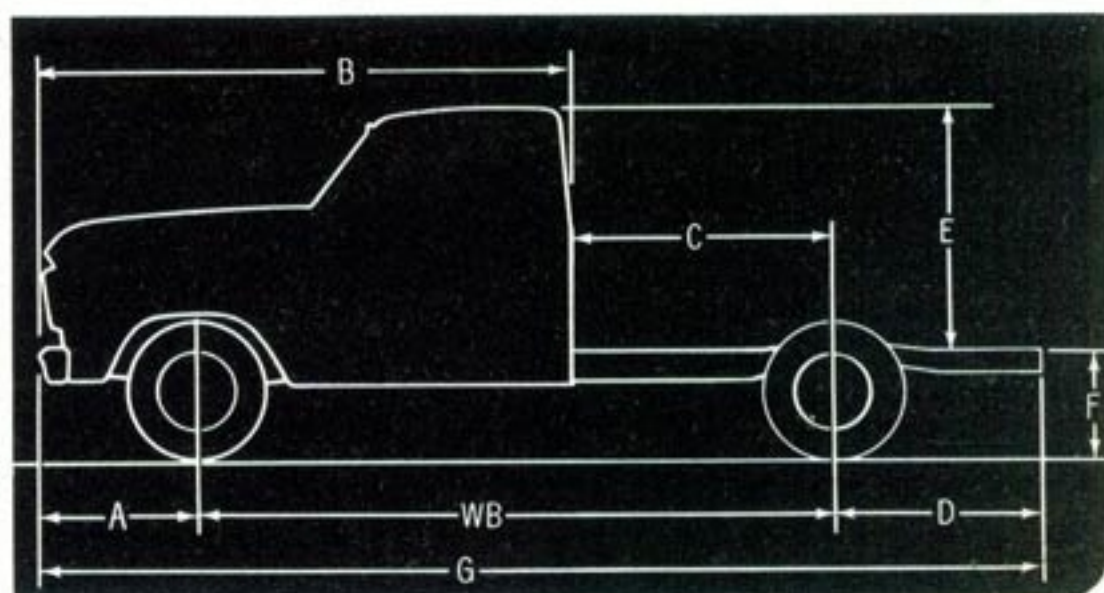

4 Seasons of fun with Ford Camper Specials

Every year more and more families are discovering that a Ford Camper Special is the reliable way to enjoy America's great outdoors. Ford F-100/250/350 Camper Specials are specially designed and engineered to carry your camper and equipment with optimum reliability, durability and economy.

You can take off on weekend or vacation hunting, fishing or camping trips in your Camper Special by Ford . . . America's leader in recreation-type vehicles. The new '67 Camper Special Package is now available on a new 135-

inch wheelbase F-350 chassis-cab model that can carry a 12-ft. cab-over camper body. The 159-inch wheelbase model, as illustrated, can haul up to a 14-ft. cab-over camper body.

Ford Camper Specials are engineered to provide the special heavy-duty components needed to haul a camper body. They remove the guesswork and bother of ordering components individually. Your Ford Dealer will be glad to assist you in selecting the Ford Camper Special model and a camper body to meet your recreational needs!



F-350 Chassis-Cab Camper Special with 14-ft. Chassis-mounted Camper

FORD
The '67-

F-100 CAMPER SPECIAL

F-100 Camper Special pickups are engineered to carry 8-foot camper coaches with optimum reliability and economy. The new, longer 131-inch wheelbase locates the center of gravity further forward of the rear axle to transfer more of the camper's weight to the Twin-I-Beam front suspension. Result—greater stability, better ride and handling, improved smoothness, more comfort and greater durability. (See chart below for details on F-100 Camper Special Package.)

F-250 CAMPER SPECIAL

F-250 Styleside and Flareside pickups and Chassis-Cab Camper Special models are designed to carry 10½-ft. cab-over camper coaches. F-250 Fords can carry over a ton more camper body and payload than F-100 models. F-100/250 Camper Specials are available with a 300-cu. in. Big Six or 352-cu. in. V-8 engine, 4-speed manual or SelectShift Cruise-O-Matic transmission, limited-slip rear axle, power steering, power brakes, Custom Cab or Ranger, air conditioner and many other options.

F-350 CAMPER SPECIAL

The F-350 135-inch wheelbase Camper Special can carry up to a 12-ft. cab-over chassis-mounted camper body. When equipped with single rear wheels, the maximum Gross Vehicle Weight is up to 8,000 pounds.

The 159-inch wheelbase F-350 Chassis-Cab Camper Special can carry up to a 14-ft. chassis-mounted cab-over camper (illustrated). When equipped with dual rear wheels, the maximum Gross Vehicle Weight is 10,000 pounds.



F-250 Camper Special with 10½-ft. Cab-over Camper



F-100 Camper Special with 8-ft. Camper

F-100/250/350 CAMPER SPECIAL PACKAGE (Pickups & Chassis-Cabs)

Camper Special Package Includes:

- 70 ampere-hour battery
- Oil pressure gauge
- Ammeter
- Dual electric horns
- Dual bright-metal 6" x 10" Western-type mirrors
- Extra cooling radiator
- Extended tailpipe
- Camper wiring harness*
- Rear shock absorbers for F-350
- "Camper Special" emblem

*Includes 12-volt 5-wire (identified) sealed cable without connectors for camper body interior and exterior lighting.

Minimum Optional Equipment Required:

The following chart shows the minimum equipment required for use with the Camper Special Package. The equipment shown does not necessarily represent the maximum equipment obtainable and in many cases additional optional equipment is available for maximum Camper loads and applications.

	F-100 (131" wb.)	F-250 (131" wb.)	F-350 (SR) 135" OR 159" wb.	F-350 (DR) 135" OR 159" wb.
Engine	300 Six or 352 V-8	300 Six or 352 V-8	352 V-8	352 V-8
Transmission	4-Spd. or Cruise-O-Matic			
Alternator	55 Ampere	55 Ampere	55 Ampere	55 Ampere
Fuel Tank	25 gal. w/ or w/o standard tank (Includes stone shield)			
Springs (lb.) Front	1175 w/Six; 1250 w/V-8	1175 w/Six; 1250 w/V-8	—	—
Rear	1250	2450	2400	3000
Aux.	—	—	—	550
†Tires—Front	8.15 x 15 8PR PT	8.00 x 16.5 6PR*	8.75 x 16.5 10PR	8.00 x 16.5 6PR
Rear & Spare	8.15 x 15 8PR PT	8.00 x 16.5 10PR*	8.75 x 16.5 10PR	8.00 x 16.5 10PR
	or	or	or	or
Front	7.00 x 15 6PR	7.50 x 16 6PR‡	7.50 x 16 6PR	7.50 x 16 6PR
Rear & Spare	7.00 x 15 6PR	7.50 x 16 8PR‡	7.50 x 16 10PR	7.50 x 16 6PR
Max. Camper Length	8 ft.	10½ ft.	w/135" 11 ft. w/159" 12 ft.	w/135" 12 ft. w/159" 14 ft.

*For maximum GVW 8.75 x 16.5 10PR or 9.50 x 16.5 8 PR front, rear and spare

‡For maximum GVW 7.50 x 16 10PR front, rear and spare or rear and spare

†Includes HD brakes on F-250

(SR)—Single rear wheels

PT—Passenger-type; all others Truck-type

(DR)—Dual rear wheels

Total Performance Ford Engines

Two High Displacement Sixes and a power-packed V-8 are available with 1967 F-100/250/350 Series Fords to provide you with high performance and long-term durability and dependability. The 150-horsepower, 240-cu. in. Six is standard with all three series; the 300-cu. in. Big Six rated at 170 horsepower is optional. Both Sixes feature a 7-main-bearing crankshaft for smoothness and stability and individual intake and exhaust manifold ports for improved engine breathing and fuel economy.

The 240- and 300-cu. in. Sixes are true High Displacement engines—engines with sufficient power and torque to enable you to maintain highway speeds while operating in the economy rpm ranges without excessive engine speeds or strain. Result: you benefit with more miles per gallon, longer engine life, less engine downtime.

Ford six-cylinder engine features include:

- Integrally cast crankshaft counterweights for smoothness and stability
- Individual pedestal-mounted ball-pivot-type rocker arms for uniform valve action at all engine speeds
- Hydraulic valve lifters for a quieter running engine and less maintenance

- Rotor-type oil pump for more effective lubrication at idling speeds than is possible with a gear-type oil pump
- Full-circle water jackets to better dissipate combustion heat
- Aluminum-alloy pistons with steel struts for controlled expansion, precise fit and long life

The 352-cu. in. V-8

The big 352-cu. in. V-8 gives you top performance . . . and good fuel economy, too! Rated at 208 horsepower, this optional V-8 is exceptionally responsive in any operating situation.

Outstanding engine features that provide this V-8 with superior performance include the following:



300-cu. in. Big Six

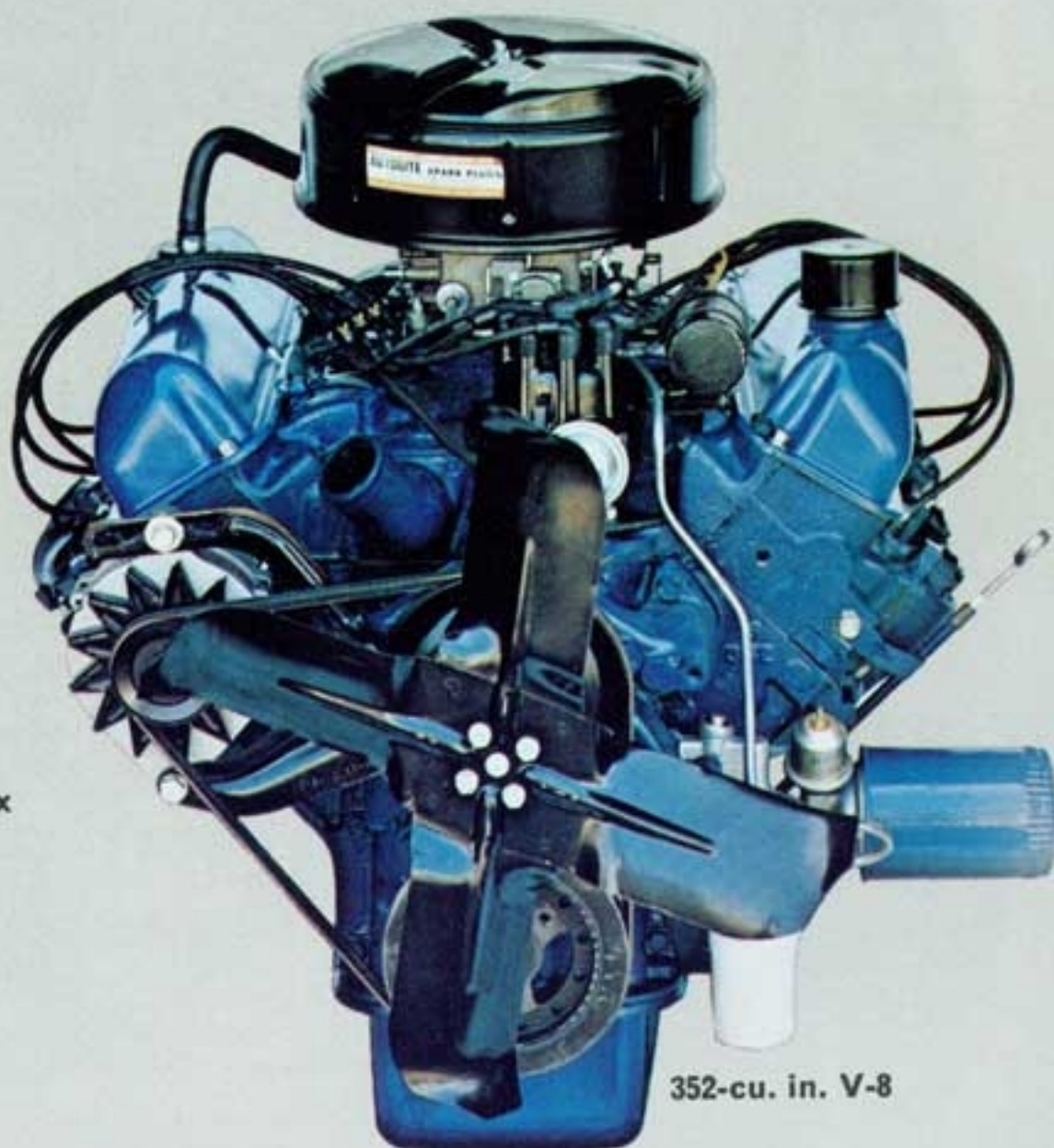

352-cu. in. V-8

BIG TRUCK POWER—SIX OR V-8

ENGINE SPECIFICATIONS	240 SIX	300 SIX	352 V-8
MAX. GROSS HP @ RPM	150 @ 4000	170 @ 3600	208 @ 4400
MAX. NET HP @ RPM	129 @ 4000	150 @ 3600	172 @ 4000
MAX. GROSS TORQUE (LBS-FT @ RPM)	234 @ 2200	283 @ 14-2400	315 @ 2400
MAX. NET TORQUE (LBS-FT @ RPM)	218 @ 2000	272 @ 14-2100	295 @ 2000
BORE AND STROKE (IN.)	4.0 x 3.18	4.0 x 3.98	4.0 x 3.50
COMPRESSION RATIO (TO 1)	9.2	7.9	8.9

6000-MILE lubrication maintenance schedule . . . Under normal operating conditions, F-100/250/350 Series Fords require oil change, oil filter change, oil-bath air cleaner service and minor chassis lubrication only every 6,000 miles.

Consult your Ford Dealer for other scheduled services.

- Precision-cast crankshaft with induction-hardened journals for extreme toughness
- High quality oil rings with chrome-plated rails for greater wear resistance
- Deep-skirt aluminum-alloy pistons for greater durability
- Hydraulic valve lifters for quieter operation and less maintenance
- Rotor-type oil pump for positive oil delivery at idling speeds
- Full-circle water jackets for more even expansion, less distortion and wear
- Large free-turn type intake and exhaust valves for self-cleaning and long life service
- Precision-machined camshaft for long cam life, smooth valve operation

STANDARD COLORS: Rangoon Red, Pebble Beige, Raven Black, Springtime Yellow, Holly Green, Lunar Green, Frost Turquoise, Harbor Blue, Wimbledon White, Chrome Yellow, Pure White. *Regular Two-Tone Paint Option* available with F-100/250/350 Series includes Wimbledon White applied to entire cab roof including drip rails and entire back panel above belt line molding and extending around cab corners to door openings.

Deluxe Two-Tone Paint Option available with F-100 and 250 Styleside Pickups includes Wimbledon White applied to the sheetmetal below the side molding and lower tailgate section. All other sheetmetal will be painted the basic color selected. This package includes bright body side molding, lower tailgate molding and taillight bezels and is also offered in combination with the regular two-tone paint option. (See above.)

POPULAR OPTIONS: F-100/250/350

- Custom Cab ■ Bucket Seats ■ Camper Special Package ■ 3-Speed SelectShift Cruise-O-Matic Transmission ■ 4-Speed Manual Transmission (F-100 & 250) ■ Integral-type Power Steering (F-100 & 250) ■ 25-Gal. Under-cab Fuel Tank and Stone Shield (w/ or w/o standard tank) ■ HD Black Vinyl Seat Trim ■ Cargo Area Light (Ranger) ■ Convenience Lighting Package (Courtesy light door switches and cargo area light) ■ Radio & Antenna ■ Dual Electric Horns ■ Shoulder Safety Harness (cabs only) ■ Two-Tone Paint ■ Deluxe Two-Tone Paint for F-100 & 250 Styleside Pickups ■ Orscheln Parking Brake Lever (250) ■ Air Conditioner (dealer installed) ■ Limited-Slip Differential ... and many more.

F-100/250 CHASSIS SPECIFICATIONS

F-100 MAX. GVW: 5,000 LB.
F-250 MAX. GVW: 7,500 LB.

	STANDARD EQUIPMENT		OPTIONAL EQUIPMENT	
	F-100	F-250	F-100	F-250
Alternator:	38 amp., 570 watt	38 amp., 570 watt	45 amp., 55 amp., 65 amp.	45 amp., 55 amp., 65 amp.
Axle, Front: Twin-I-Beam Capacity (lb.)	2600	3000	—	—
Axle, Rear: Capacity (lb.)—Ratios (to 1)	3300—3.70	5200—4.10	3300—3.25, 3.50, 4.11 3.31, 3.54, 3.73, 4.09	5200—3.73, 4.56
			3600—3.54, 4.10	3.73, 4.10, 4.56
Battery: (12 volt)	54 plates—45 amp-hr	54 plates—45 amp-hr	66 plates—55 & 70 amp-hr	66 plates—55 & 70 amp-hr
Brakes, Service: Dual hydraulic master cylinder system	Self-adjusting	Self-adjusting	—	HD self-adjusting
Size (in.) front	11 x 2	12 1/4 x 2	—	12 x 2 1/2
rear	11 x 1 1/4	12 1/4 x 2	—	12 x 2 1/2
Brake Equipment:	—	—	6 1/4" dia. vacuum booster	6 1/4" dia. vacuum booster
Brakes, Parking: Type (foot-operated*)	Cable actuation of rear brakes	Cable actuation of rear brakes	—	—
Clutch: Dia. (in.)—Area (sq. in.)	HD 11—123.7"	HD 11—123.7"	—	—
Engine:	240-cu. in. Six	240-cu. in. Six	300-cu. in. Six 352-cu. in. V-8	300-cu. in. Six 352-cu. in. V-8
Frame: Section Modulus	115" wb.—2.98; 131" wb.—3.06	3.89	—	—
Shock Absorbers: Front and rear	Double-acting	Double-acting	—	—
Springs, Front: Coil capacity @ pad (lb. each)	1055 (240, 300 Sixes) (1175 w/352 V-8)	1055 (240, 300 Sixes) (1175 w/352 V-8)	1175 (240, 300 Sixes) 1250 (352 V-8)	1175 (240, 300 Sixes) 1250 (352 V-8)
Springs, Rear: (Progressive leaf-type)	—	—	—	—
Capacity @ pad (lb. each)	950	1450	1250, 1650† 380 (N.A. w/1650 main)	1950, 2450 450 (N.A. w/std. main)
Auxiliary	—	—	—	—
Radiator:	—	—	Extra cooling	Extra cooling
Steering: Type	Recirculating ball	Recirculating ball	Power, integral type	Power, integral type
Transmission: Type	3-speed fully synchronized	3-speed fully synchronized	3-speed plus Overdrive 4-speed & Cruise-O-Matic	4-speed Cruise-O-Matic
Wheels: No.—type—rim size (in.)	5—5-hole disc—5 1/2 K	5—8-hole disc—6.0	16 x 5K, 15 x 5.50K HD	16 x 5.50F, 16.5 x 6.0 & 6.75, 17.5 x 5.25
Tires: Tubeless, No.—size	5—8.15 x 15 4PR PT	4—8.00 x 16.5 6PR	Tubeless and tube-type tires in sizes to match requirements	Tubeless and tube-type tires in sizes to match requirements

Note: Use adequate tires for loads and type of service. Consult your Ford Dealer!

*Orscheln lever optional w/HD brakes on F-250 †Single-stage type

F-350 CHASSIS SPECIFICATIONS (135- and 159-inch wheelbases)

MAX. GVW: 8,000 LB. w/SINGLE REAR TIRES
10,000 LB. w/DUAL REAR TIRES

	STANDARD EQUIPMENT	OPTIONAL EQUIPMENT
Alternator:	38 amp.—570 watt	45, 55 or 65 amp.
Axle, Front: (Twin-I-Beam) Capacity (lb.)	3800	—
Axle, Rear: Capacity (lb.)—Ratios (to 1)	7400—4.56	4.10, 4.88
		4.10, 4.56, 4.88
Battery: (12 volt)	54 plates—45 amp-hr	66 plates—55 amp-hr 66 plates—70 amp-hr
Brakes, Service: Dual hydraulic master cylinder system	Self-adjusting	9" dia. vacuum brake booster
Size (in.) front—rear	12 x 3	—
Brakes, Parking: Type (foot-operated)	Cable actuation of rear brakes	—
Clutch: Diameter (in.)—Area (sq. in.)	HD 11"—123.7	—
Engine:	240 Six	300 Six; 352 V-8
Frame: Section Modulus	135" wb.—5.58; 159" wb.—7.84	—
Shock Absorbers: Double-acting	Front	Rear, HD Front
Springs, Front: Coil capacity @ pad (lb. ea.)	1365 w/Six, 1455 w/V-8	—
Springs, Rear: Progressive capacity @ pad. (lb. each)	1700	2400, 3000
Auxiliary	—	550
Steering: Type	Recirculating ball-type	—
Transmission: Type	4-speed NP 435 (direct)	3-speed Cruise-O-Matic
Wheels:	Single rear	Single or dual rear
Tires: Tubeless*, No.—Size	4—8.00 x 16.5 (6PR front & 8PR rear)	Tubeless and tube-type tires in sizes to match requirements

Note: Use adequate tires for loads and type of service. Consult your Ford Dealer!

*Tubetype also available

Other Light-Duty Ford Pickups to choose from...

Ford light-duty vehicles for work or pleasure: **Bronco** . . . Ford's all-purpose, 4-wheel-drive vehicle is available as

Wagon, Pickup or Roadster; **F-100 and 250 4x4's** are bigger 4-wheel-drive vehicles designed for heavier on- or off-highway service. These 4-wheel-drive Fords can take you virtually anywhere . . . perform special chores with power take-off driven equipment . . . substitute as recreation vehicles on weekends. Other two-wheel drive pickups include

Fairlane Ranchero . . . Ford's newest prestige pickup available in three series, the Fairlane, Fairlane 500 and Fairlane 500/XL, with up to 320 horsepower, and **Econoline Pickup** . . . Ford's economy compact pickup! No matter what your light hauling job may be, Ford's tough light-duties are designed to meet your needs best!



BRONCO PICKUP



FAIRLANE 500/XL RANCHERO



F-250 4 X 4 STYLESIDE PICKUP



ECONOLINE PICKUP

FORD MOTOR COMPANY'S "3-Point Warranty Plan"

1. 5-year or 50,000-mile warranty on the power train, 2. 2-year or 24,000-mile warranty on complete vehicle, 3. Only one dealer certification per year regardless of how many miles you drive.

Ford Motor Company warrants to owners that their selling Ford dealer (or if the owner is traveling or has moved, any Ford dealer), using genuine new Ford or Ford Authorized Reconditioned parts, will repair or replace, free of charge including related labor, the following parts in Ford light trucks and Broncos which are found, in normal use and within the following time and mileage limits (whichever comes first), to be defective in either workmanship or materials: (a) any part within 24 months or 24,000 miles, and (b) Power Train parts within 5 years or 50,000 miles.

Power Train parts include: engine block, head and internal parts, water pump, intake manifold, transmission and transfer cases and internal parts, torque converter, driveshafts, universal joints, differentials, and driving axles and their wheel bearings. Related items such as ignition, electrical, cooling, fuel and brake systems, engine or transmission controls or linkages, and clutch assembly are excluded. The owner is required to obtain certain maintenance services* and, every 12 months, a written

certification from a Ford dealer that he has presented evidence that such services have been performed.

The warranty does not apply to tires or tubes (adjustments are provided by tire companies), or to normal maintenance services or normal replacement of service parts such as filters, spark plugs, ignition points, wiper blades or brake or clutch linings, or to normal deterioration of soft trim and appearance items.

The warranty applies to vehicles normally operated in the U.S.A. and Canada.

*Every 6 months or 6,000 miles: change oil and oil filter; clean air cleaner, air filter and oil filler cap; check axle lube and transmission oil levels. Every 12 months or 12,000 miles: replace air filter on closed crankcase ventilation systems; clean emission system and carburetor spacer; replace emission control valve and thermactor air filter. Every 24 months or 24,000 miles: change engine coolant and check radiator hoses. Every 36 months or 36,000 miles: replace air filter on open crankcase ventilation systems; adjust automatic transmission bands.

The specifications contained herein were in effect at the time this catalog was approved for printing. The Ford Division of Ford Motor Company reserves the right to discontinue models at any time or change specifications or design without notice and without incurring obligation. All options and accessories illustrated or referred to as optional or available in this catalog are at extra cost. For the price of the model with the equipment you desire, see your Ford Dealer.

Every 1967 FORD TRUCK has been designed, engineered and quality-built to provide safer, more dependable service than ever. Ford Motor Company Lifeguard-Design light truck, Bronco, Econoline and Fairlane Ranchero safety features are standard equipment in every 1967 model described in this catalog. Safety also depends upon the proper operation and maintenance of a vehicle . . . and the continued use of the safety equipment provided.

YOU'RE AHEAD IN A FORD ALL THE WAY!

