



# Modems

**Canoga Perkins  
2270  
Fiber Optic Modem  
User Manual**

## Notice!

Canoga Perkins has prepared this manual for use by customers and Canoga Perkins personnel as a guide for the proper installation, operation and/or maintenance of Canoga Perkins equipment. The drawings, specifications and information contained in this document are the property of Canoga Perkins and any unauthorized use or disclosure of such drawings, specifications and information is prohibited.

Canoga Perkins reserves the right to change or update the contents of this manual and to change the specifications of its products at any time without prior notification. Every effort has been made to keep the information in this document current and accurate as of the date of publication or revision. However, no guarantee is given or implied that the document is error free or that it is accurate with regard to any specification.

Canoga Perkins Corporation  
An Inductotherm Company  
20600 Prairie Street  
Chatsworth, CA 91311-6008  
(818) 718-6300  
FAX: (818) 718-6312  
Web Site: [www.canoga.com](http://www.canoga.com)  
e-mail: [fiber@canoga.com](mailto:fiber@canoga.com)

Copyright 1988, 1990, 1991, 1992, 1996, 1998 Canoga Perkins  
All Rights Reserved

2270 Fiber Optic Modem  
6910321 Rev. D 5/98



## Caution!

This product may contain a laser diode emitter operating at a wavelength of 1300 nm - 1600 nm. Use of optical instruments (for example: collimating optics) with this product may increase eye hazard. Use of controls or adjustments or performing procedures other than those specified herein may result in hazardous radiation exposure.

Under normal conditions, the radiation levels emitted by this product are under the Class 1 limits in 21 CFR Chapter 1, Subchapter J.



## Notice!

**This device contains static sensitive components. It should be handled only with proper Electrostatic Discharge (ESD) grounding procedures.**

# Table of Contents

---

<b>Chapter 1 - General</b> .....	<b>8</b>
<b>1.1 Equipment Description</b> .....	<b>8</b>
<b>1.2 Functions, LEDs and Switches</b> .....	<b>8</b>
<b>1.3 2201 Rack Chassis</b> .....	<b>10</b>
<b>1.4 2202 Modem Shelf</b> .....	<b>10</b>
<b>1.5 2200R Redundant Modem Card Set</b> .....	<b>10</b>
<b>1.6</b> .....	<b>Fiber Optic Versions 10</b>
<b>1.7 Loss Budget</b> .....	<b>11</b>
<b>1.8 Optical Bandwidth</b> .....	<b>11</b>
<b>1.9 General Installation</b> .....	<b>11</b>
1.9.1 Fiber Optic Cable and Connectors .....	11
1.9.2 Initial Unit Testing .....	11
<b>1.10 Sensitivity and Optical Power Switches (HP Laser Version Only)</b> .....	<b>12</b>
1.10.1 Optical Power Switch (HP Laser Version Only) .....	12
1.10.2 Sensitivity Switch (HP Laser Version Only) .....	12
1.10.3 Optical Switch Settings (HP Laser Version Only) .....	12
1.11 Switch and Jumper Settings .....	13
1.12 Mean Time Between Failures (MTBF) .....	13
<b>Chapter 2 - Installation</b> .....	<b>16</b>
<b>2.1 Unpacking the Unit</b> .....	<b>16</b>
<b>2.2 Standalone Modem Installation</b> .....	<b>16</b>
<b>2.3 2202 Modem Shelf Installation</b> .....	<b>16</b>
<b>2.4 Fiber Cable and Connectors</b> .....	<b>17</b>
<b>2.5 DC Power</b> .....	<b>17</b>
<b>2.6 Rack Chassis Installation</b> .....	<b>18</b>
<b>2.7 Mode and Rate Selection</b> .....	<b>18</b>
2.7.1 External Clock Operation .....	18
2.7.2 Internal Clock Operation .....	18
2.7.3 Asynchronous Operation .....	20
2.7.4 Data Rates .....	20
2.7.5 Data Rate vs. Module Frequency .....	20
2.7.6 Slave Clock Operation .....	20
<b>2.7.7 Consideration of Propagation Delays</b> .....	<b>20</b>
<b>Chapter 3 - Data Interfaces</b> .....	<b>23</b>
<b>3.1 Electrical Data Interfaces</b> .....	<b>23</b>
<b>3.2 RS-232C/423 Interface Model -32</b> .....	<b>23</b>
<b>3.3 RS-449/422 Interfaces</b> .....	<b>23</b>
<b>3.3.1 Model -22</b> .....	<b>25</b>
<b>3.3.2 Model -H22</b> .....	<b>25</b>
<b>3.3.3 Model -R2R</b> .....	<b>25</b>
<b>3.4 RS-530 Interface Model -R30</b> .....	<b>26</b>
<b>3.5 T1/E1 Interfaces</b> .....	<b>28</b>
3.5.1 Transparent Bipolar Models -B1, -B2, -B3 .....	28

---

3.5.2 DS1 / T1 Model -T1 .....	30
<b>3.6 TTL/BNC Interface Model -BN .....</b>	<b>30</b>
<b>3.8 .....</b>	<b>32</b>
3.8.1 Generic Interface .....	36
3.8.2 External Station .....	37
3.8.3 Internal .....	38
3.8.4 External .....	39
3.8.5 DTE Adapter .....	40
3.8.6 Legacy Adapter .....	41
<b>3.9 High-Speed RS-422/Mil-Std 188-114C Interfaces .....</b>	<b>42</b>
3.9.1 Model -TW .....	43
3.9.2 Model -TW8 .....	44
3.9.3 Model -T22 .....	44
3.9.4 Model -T88 .....	44
3.9.5 Model -D22 .....	44
3.9.6 Model -D88 .....	44
<b>3.10 Interface Reconfiguration .....</b>	<b>46</b>
<b>3.11 Standalone Reconfiguration .....</b>	<b>46</b>
<b>Chapter 4 - Modem Operation .....</b>	<b>47</b>
<b>4.1 Modem Operation .....</b>	<b>47</b>
<b>4.2 Fiber Optics .....</b>	<b>47</b>
<b>4.3 Transmit Section .....</b>	<b>48</b>
<b>4.4 Receive Section .....</b>	<b>48</b>
<b>4.5 Full Rate Agility .....</b>	<b>48</b>
<b>4.6 Bit Count Integrity .....</b>	<b>49</b>
<b>4.7 Duty Cycle Tolerance .....</b>	<b>49</b>
<b>4.8 Control Signals .....</b>	<b>49</b>
4.8.1 Flow Control .....	50
<b>Chapter 5 - Troubleshooting .....</b>	<b>51</b>
<b>5.1 Diagnostic Procedures .....</b>	<b>51</b>
<b>5.2 System Test .....</b>	<b>51</b>
5.2.1 Local Loopback Test .....	53
5.2.2 Remote Loopback Test .....	54
5.2.3 System Loopback Test .....	55
<b>Chapter 6 - Diagnostic Procedures .....</b>	<b>56</b>
<b>6.1 2270/2201 Diagnostic Procedures .....</b>	<b>56</b>
<b>6.2 System Test Diagnostic Procedure .....</b>	<b>56</b>
<b>Chapter 7 - Specifications .....</b>	<b>58</b>
<b>7.1 Diagnostic Indicators and Controls .....</b>	<b>58</b>
<b>7.2 Optical Interface .....</b>	<b>58</b>
<b>7.3 System Electrical .....</b>	<b>59</b>
<b>7.4 Physical Dimensions .....</b>	<b>59</b>
<b>7.5 2270 Fiber Optic Modem Configurations .....</b>	<b>60</b>
<b>Appendix A .....</b>	<b>61</b>
<b>A.1 Customer Service Department Repair .....</b>	<b>61</b>
<b>Warranty .....</b>	<b>61</b>
<b>A.2 Return Policy .....</b>	<b>61</b>

**A.3 Advance Replacement Policy ..... 61**  
**A.4 Warranty ..... 62**  
    Electronic Products ..... 62  
    Cable Products ..... 62  
    Limitations ..... 62

## List of Figures

Figure	Page
1-1 Front Panel Mode/Rate Switch .....	9
1-2 Locations of Various Switches .....	13
2-1 Model 2202 Standalone Modem Shelf .....	16
2-2 2201 Rack Chassis Front View with Modems Installed .....	19
3-1 2270 Interchangeable Interfaces .....	23
3-2 Transparent Bipolar Interface Connectors .....	29
3-3 Available Strapping Options for Programmable Buffered Interface .....	33
3-4 Board Layout and Modules for Programmable Buffered Interface .....	34
3-5 Programmable Buffered Interface, Model P53, DCE RS-530 .....	36
3-6 Programmable Buffered Interface, Model P53, External Station .....	37
3-7 Internal Programmable Buffered Interface, Model P53, RS-530 .....	38
3-8 External Programmable Buffered Interface, Model P53 .....	39
3-9 Programmable Buffered Interface, Model P53 [DTE] .....	40
3-10 Programmable Buffered Interface, Model P53 [Legacy Adapter] .....	41
3-11 BNC and Four TwinAx Connectors (BJ-77 Type) .....	44
3-12 Five TwinAx Connectors (BJ-77 Type) .....	45
3-13 Interface Card Installation .....	46
4-1 2270 Circuit Block Diagram .....	47
4-2 Typical High Speed 2270 Modem Application .....	48
4-3 Data Organization with PWM Optics .....	49
5-1 System Loopback Test Example From User-End of Fiber Link .....	51
5-2 “Bi-Directional” Local Loopback Active .....	53
5-3 “Interface Only” Local Loopback Active .....	53
5-4 “Optical Only” Remote Loopback Active .....	53
5-5 “Bi-Directional Only” Remote Loopback Active .....	54
5-6 “Optical at Local End” Loopback Active .....	54

## List of Tables

Table	Page
1-A Available Modem Controls .....	8
1-B Guaranteed Loss Budgets .....	10
1-C 2270 Switch Functions .....	14
1-D 2270 Jumper Functions .....	15
2-A Operating Mode Selections .....	19
2-B Data Rate Switch Position vs. Oscillator Part Number .....	21
3-A RS-232C/423 Signals and Pin Assignments .....	24
3-B Available Models of RS-449/422 Interfaces .....	24
3-C RS-449 (RS-422) Signals and Pin Assignments .....	25
3-D RS-530 Signals and Pin Assignments .....	26
3-E RS-530 Jumper Options .....	27
3-F Transparent Bipolar Line Interfaces .....	28
3-G Line Build Out Settings .....	29
3-H CCITT V.35 Digital Interface and Pin Assignments .....	31
3-I Delay Times for Programmable Buffered Interface .....	34
3-J Strap Configurations for Programmable Buffered Interface .....	35
3-K TwinAx and BNC Supported Signals .....	42
3-L Model Characteristics .....	42
3-M Jumper Strap Options .....	43
3-N Models D22 and D88 Connector Pin Assignments .....	45
5-A Loopback Options .....	52



# Chapter 1 - General

---

## 1.1 Equipment Description

The 2270 is a high-speed modem for full-duplex operation over fiber optic cable. It operates synchronously up to 20 Mbps, and asynchronously up to 5 Mbps in the sample-data mode with a 25% jitter limit. The 2270 is available in rack-mount and standalone configurations. Both are intended to operate with a variety of electrical interfaces (refer to Section 7.5, "2270 Fiber Optic Modem Configurations," for a listing of the interface options for the 2270). Refer to Section 3 for detailed descriptions of available I/O interfaces.

The 2270 has integral System Test and loopback diagnostic modes for performance monitoring. Various 2270 configurations provide local modem controls, including those listed in Table 1-A. A limited form of end-to-end control lead operation is also available (refer to Section 4.8).

## 1.2 Functions, LEDs and Switches

The 2270 standalone modems do not have an on/off switch, since they power up when plugged in. For 2270 Rack-Mount configurations, a power supply on/off switch is located at the rear of each power supply assembly on the 2201 Rack Chassis.

An eight-section switch bank, located on the front panel of the 2270 (see Figure 1-1), controls all operating modes and internal clock rates.

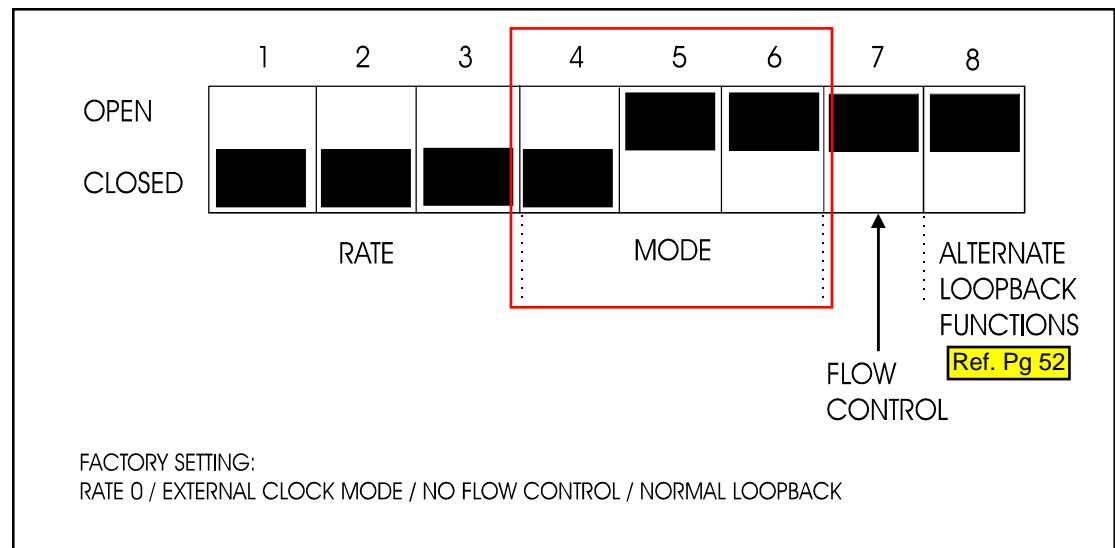
Switch positions 1, 2 and 3 select the internal clock operating rates. Refer to Table 2-B for data rate switch settings. The rates depend on the crystal option installed. Refer to Section 7.5 for a list of crystal options available. The -08 crystal is installed as the factory default crystal unless an alternate crystal is ordered.

**Table 1-A. Available Modem Controls**

<b>DATA/CLOCK</b>	<b>CONTROLS</b>
TRANSMIT DATA	REQUEST TO SEND
RECEIVE DATA	CLEAR TO SEND
TRANSMIT CLOCK	DATA CARRIER READY
RECEIVE CLOCK	DATA SET READY



**Figure 1-1.**  
**Front Panel**  
**Mode/Rate**  
**Switch**



The rate setting determines what rate the modem will operate at if set to the Internal Clocking Mode or the rate used when a modem set to the Slave Clocking Mode is set for local loopback.

The modes are:

- External Clock
- Internal Clock
- Slave Clock
- Flow Control
- Alternate Loopback Functions

Switch positions 4, 5 and 6 select the clocking mode for the modem as described in Section 2.7 and shown in Table 2-A.

Switch position 7 selects whether the RTS input controls flow control through the modem (Open = no flow control, Closed = flow control enabled). Refer to Section 4.8.1.

Switch position 8 selects the normal or alternate loopback mode as shown in Table 5-A of the Troubleshooting section.

Indicator lights are provided for Power On, Optical Receive and Transmit data activity, Interface Receive and Transmit data activity, and for Loopback On. All of these indicators are located on the front panel, for both standalone and rack-mount versions.

The loopback switch on the front panel is used to activate the built-in system test or to select either a Local or Remote loopback function. Use of this switch is outlined in Chapter 5, "Troubleshooting."

The electrical interface connection and fiber optic connections are made at the rear of the modem. The HI/LO optical power switch is also located there.

There is also a HI/LO switch for the optical receiver, used to select its sensitivity. Operating this switch in the LO position may be necessary under certain low-loss conditions (refer to Section 1.9).

### 1.3 2201 Rack Chassis

The 2201 Rack Chassis is designed to accommodate up to ten 2200 series modems.

It offers a variety of features, including local audible/visible and remote power failure alarms, optional redundant power supply, and the ability to allow modem removal from the chassis without powering down the entire system. Refer to the 2201 Rack Chassis / 2200R Redundant Modem Card User Manual for more details.

### 1.4 2202 Modem Shelf

The 2202 Modem Shelf accommodates one or two standalone 2200-series modems. It is designed to fit easily into a 19-inch equipment rack. The modems can be secured side-by-side in the shelf. Refer to the 2202 Modem Shelf User Manual for more details.

### 1.5 2200R Redundant Modem Card Set

A redundant board set, consisting of two 2270 Modems and a 2200R Modem Card, uses three slots of the 2201 Rack Chassis. It enables a user to incorporate a fully redundant fiber optic link with 2270 Modems. The combination of the three boards provides redundant operation for data rates up to 20 Mbps. Redundancy is not available for standalone models.

The 2200R provides the redundancy controller and signal switch for a redundant board set. The 2200R is equipped with keyed-ribbon cables and a modem interface (RPB) extender for easy installation. Refer to the 2201 Rack Chassis / 2200R Redundant Modem Card User Manual for more details.

### 1.6 Fiber Optic Versions

Three fiber optic versions provide solutions to virtually any fiber-optic plant, including 50/125 or 62.5/125 multimode and 8-10/125 single mode. Table 1-B summarizes the three fiber-optic versions.

**Table 1-B. Guaranteed Loss Budgets**

Optics Option	Fiber Size			
	8/10 SM	50 MM	62.5 MM	Min. Launch Power dBm
850 nm LED	N/A	2	6	-14
1310 nm LP Laser	10	10	10	-8
1310 nm HP Laser	15	15	15	-6
[Typical loss budgets are 2 dB higher]				
N/A = Not Applicable				

## 1.7 Loss Budget

The maximum possible distances with either standard or long distance versions is dependent on the overall power loss over the fiber optic link. This is called the link loss. The launch power for the modem is compared with receiver sensitivity. The determination of the difference is the loss budget (refer to Table 1-B). To insure normal operation over a long term, the link loss should be at least 3 dB less than the loss budget for the modem.

For example, consider a data link 7 kilometers long using 50/125 optical fiber that has a measured power loss of 9 dB, and a patch panel connector loss of 3 dB, for a total link loss of 12 dB.

The minimum launch power of the 2270 High Power (HP) laser version is -6 dBm in high-power mode, and the worst-case receiver sensitivity is -21 dBm. The guaranteed loss budget is 15 dB. Subtracting the link loss (12 dB) from the loss budget (15 dB) leaves a margin of 3 dB -- is within the suggested limit.

**NOTE: Optical power measurements for the 2270 are sensitive to the data rate. All measurements quoted are for a 20 Mbps data rate.**

## 1.8 Optical Bandwidth

The 2270 requires nearly 70 MHz of optical bandwidth. As a result, the specified fiber optic cable must provide this bandwidth at the required distance.

For example, if 500 MHz/km fiber is used, this bandwidth requirement will limit the end-to-end distance to 7 km (70 MHz multiplied by 7 km = 490 MHz).

## 1.9 General Installation

### 1.9.1 Fiber Optic Cable and Connectors

The 2270 can be used with virtually any size of multimode or single mode fiber optic cable including 50/125, 62.5/125 and 8-10/125.

The proposed fiber optic cable must provide adequate bandwidth and power loss characteristics for the intended modem link.

Fiber optic connectors terminated on the cable must match those terminated on the modem.

#### **CAUTION:**

**It is important to keep all connectors free of water, dust, dirt, etc. When not in use, the connectors should be covered with protective plastic caps.**

### 1.9.2 Initial Unit Testing

The following is a basic list of check points to consider:

- **Have you set your optical power and receiver sensitivity switches correctly for the loss of the fiber optic link?**
- **Are the fiber optic cables marked correctly? Connect the Tx cable to the Tx connector, the Rx cable to the Rx connector. If System Test fails, try swapping cables at one end of the link.**

- **Are you using the correct clock mode (internal/external) for synchronous transmission?**
- **Have the modem's mode and rate switches been set properly? (The 2270 is set to the external clock mode at the factory.)**
- **If you have problems after carefully checking these items, turn to Chapter 5, "Troubleshooting."**

## **1.10 Sensitivity and Optical Power Switches (HP Laser Version Only)**

A dual-section switch block is located between the transmit and receive optical connectors (see Figure 1-3). The section nearest the transmit connector controls the optical transmit power level. The section nearest the receiver controls the receiver sensitivity. For both switch functions, ON selects HI and OFF selects LO. For standalone modems, ON = UP and LO = DOWN; for rack mount modems, ON = RIGHT and LO = LEFT. This feature is only required for the HP laser fiber-optic version. These switches are not provided in the other fiber-optic versions.

### **1.10.1 Optical Power Switch (HP Laser Version Only)**

The Optical Power Switch (TX POWER) provides two settings for optical transmission levels. The LO switch setting is intended for use with short fiber optic lengths, i.e., a cable and connector power loss total of less than 10 dB. The HI switch setting is intended for longer cable runs, up to the maximum power loss budget.

### **1.10.2 Sensitivity Switch (HP Laser Version Only)**

The Sensitivity Switch (RX SENS) provides two settings for optical receiver sensitivity. The LO switch setting is intended for short fiber lengths in conjunction with LO optical power at the other end. The LO setting must be used with a fiber link loss of 5 dB or less.

### **1.10.3 Optical Switch Settings (HP Laser Version Only)**

The proper setting of the Optical Transmit Power and Optical Receive Sensitivity Switches are based on the loss measured on the fiber at a wavelength of 1300 nm. The 2270 should be used as an optical power source when performing these measurements.

The loss on the fiber link determines the setting of the Tx Power Switch at the transmitting end and the Rx Sensitivity Switch at the receiving end. It is important to remember that the switch settings are determined separately for each fiber in the pair.

When operating the modem at rates above 6 Mbps, the HI/HI setting can always be used. HI/HI refers to HI Tx power and HI Rx sensitivity. If the modem is to be operated below 6 Mbps, or if the application requires full rate agility (without changing switch configuration) that extends below 6 Mbps, then the settings listed below should be followed.

<b>TX PWR</b>	<b>RX SENS</b>	<b>MIN LOSS</b>	<b>MAX LOSS</b>
LO	LO	0	5
LO	HI	5	10
HI	LO	10	13
HI	HI	13	15

These settings give minimum and maximum losses for each of the four possible switch combinations. There is overlap between these ranges that is guaranteed to meet or exceed  $\pm 1.0$  dB from the transition points.

The performance of every modem is guaranteed to fit the parameters given above. Some modems may significantly exceed these performance limits, but reliable operation and unit interchangeability is not guaranteed outside of these limits.

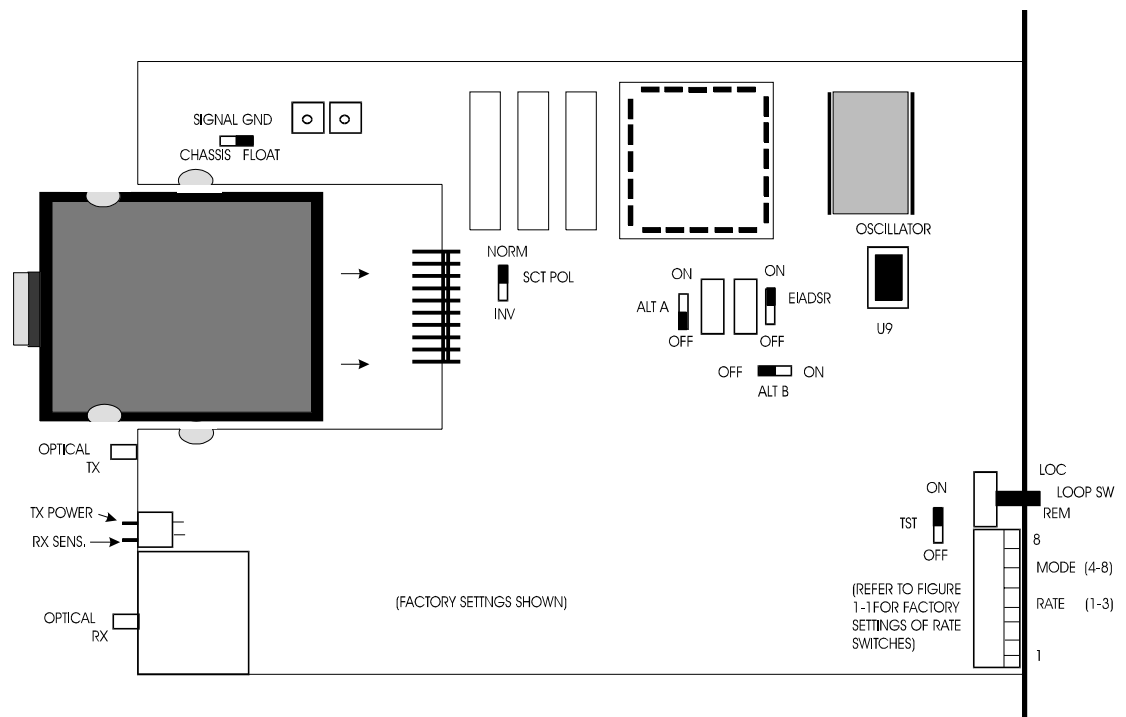
### 1.11 Switch and Jumper Settings

See Figure 1-2 for the location of specific switches and jumpers. Tables 1-C and 1-D summarize the functions of the 2270's switches and jumpers.

### 1.12 Mean Time Between Failures (MTBF)

The 2270's Mean Time Between Failures (MTBF) figure, 62,500 hours (calculated) has been determined from calculations that are similar to MIL-217E. It assumes a Ground Benign environment and excludes failures which are not service-affecting. This MTBF figure is for a Rack-Mount 2270 with a MIL-STD 188-114C interface (Model 2270-R-TW8-11-08-0).

**Figure 1-2.**  
**Locations of**  
**Various Switches**



**Table 1-C. 2270 Switch Functions**

**LOOP TEST** switch on Front Panel (described in Section 5, "Troubleshooting").

LOC position will activate a local interface loopback.

REM position will activate a System Test and control the state of the far-end loopback.

OFF position is for normal transmission.

**TRANSMIT OPTIC POWER** switch on Rear Panel (described in Section 1.9).

HI position is used for link losses from approximately 10 dB and greater.

LO position is used for link losses below 10 dB.

**RECEIVER SENSITIVITY** switch on Rear Panel (described in Section 1.9).

See NOTE 1

The position of this switch is dependent on both the loss of the Rx link and the position of the Tx optical power switch on the modem at the other end.

**CLOCK RATE** switches on Front Panel (described in Section 2).

Switches 1-3 control both the internal clock rate and the System Test rate. The rate is also dependent on the frequency of the installed oscillator.

**CLOCK MODE** switches on Front Panel (described in Section 2).

Switches 4-6 control the transmitter clock mode (external/slave/internal).

Switch 7 controls the transmitter sensitivity to RTS used for flow control.

Switch 8 enables selecting an alternate loopback method (refer to Section 5 for Loopback options).

NOTE 1: Power should be cycled after changing switch. The unit must be powered down whenever a setting is changed.

**Table 1-D. 2270 Jumper Functions****W2**

**SIGNAL GROUND** controls connecting circuit ground to the chassis.  
 CHASSIS connects them together.  
 FLOAT isolates the two grounds.

**Factory Setting = FLOAT** See page 27 note

**W3**

**SCT POLARITY** controls the transmit clock output.  
 NORM is always used for low data rates for proper clock phasing.  
 INV may be needed for internal clock or slave clock modes operating high data rates  
 if the DTE loop has long delays.

**Factory Setting = NORM**

**W16**

**TEST** controls the built-in test pattern checker.  
 ON allows System Test loopback to be activated and Remote Loopback control.  
 OFF defeats pattern loopback for System Test and disables any Remote Loopbacks.

**Factory Setting = ON**

**W6/8**

**ALT A** and **ALT B** allow alternate loopback methods to be selected. If the front panel alternate loopback switch is also considered, there are eight possible loopback responses for each end of the link.

**ALT A** affects Local Loopback, depending on the ALT loopback switch.

**Factory Setting = OFF**

**ALT B** affects Remote Loopback, depending on the ALT loopback switch.

**Factory Setting = OFF**

**W20**

**EIADSR** allows a proper DSR signal to connect to the interface.  
 ON connects the signal through interface.  
 OFF disconnects the signal from the interface. Only the DS1/T1 interface requires this selection.

**Factory Setting = ON**

## Chapter 2 - Installation

---

### 2.1 Unpacking the Unit

Each 2200 Series Modem is shipped factory tested, and packed in a protective carton. Unpack the unit and retain the shipping carton and protective packing for reuse in the event it is necessary to return the modem to the factory.

To assure proper operation of the modem, please inspect it and its shipping carton carefully for damage. If damage is sustained to the unit, immediately file a liability claim with the freight carrier. Canoga Perkins is not liable for damage in shipment.

### 2.2 Standalone Modem Installation

Installing the standalone version of the 2270 is straightforward. It should be located conveniently to the operator. The electrical and optical cables should be isolated from foot traffic to prevent possible damage.

For AC-powered units, the attached power supply for the standalone is a wall-type transformer. It should be plugged into a standard AC wall outlet that incorporates a ground line. A POWER ON switch is not provided as the modem is powered when the unit is plugged in.

### 2.3 2202 Modem Shelf Installation

Two 2270 standalone modems may be installed in an equipment rack when using the 2202 Modem Shelf. The modems may be placed side-by-side on the shelf after the shelf is mounted in the equipment rack (see Figure 2-1).

For a more secure assembly, two screws are provided to secure the modems to the shelf prior to installing the shelf in the rack.

First, on the modem that will be mounted on the left side of the shelf, remove and discard the center cover attachment screw on the left side. Position the modem so that the empty hole lines up with the one on the left side of the shelf.

Next, using one of the longer screws provided, mount the modem from the outside by threading the screw through the 2202 shelf and into the cover screw hole in the modem.



**Figure 2-1.**  
**Model 2202**  
**Standalone**  
**Modem Shelf**



Repeat this procedure for the second modem using the center cover retaining screw on the right side of the modem. After the modems are secure, you can mount the shelf into the equipment rack.

**NOTE: Depending on accessibility, it may be necessary to connect the fiber cables and interface cables before mounting the 2202 shelf in the equipment rack.**

**NOTE: The modem must always be removed from the 2202 shelf, and its top cover removed, to access any switches inside the case.**

## 2.4 Fiber Cable and Connectors

The proposed fiber optic cable must provide adequate bandwidth and power loss characteristics for the intended modem link. Furthermore, the terminated cable must match the connectors on the modems: typically, ST.

The connectors on the fiber optic cable, when supplied by Canoga Perkins, are marked Tx and Rx, and should be connected to *matching* connectors on the modem. That is, Tx to Tx, and Rx to Rx. This will link the Rx of the local modem to the Tx of the remote modem, and the Tx of the local modem to the Rx of the remote modem.

The connectors are clearly marked as to their function, either Transmit (Tx) or Receive (Rx), on the rear panel of the 2270 standalone units, and on the rear of the 2201 Rack Chassis.

**NOTE: Keep all connectors free of water, dust and dirt. Cover them and the cable ends with plastic caps when they are not mated.**

The 2270 can be used with most popular sizes of multimode and single mode optic cable, including 8-10/125, 50/125 and 62.5/125.

**NOTE: When using 85/125 or 100/140 micron fiber optic cable, an in-line attenuator may need to be installed between the 2270 and the Receive (Rx) fiber optic cable for proper modem operation on short links.**

## 2.5 DC Power

A DC-powered version is available for use with a nominal  $\pm 48$  VDC source ( $\pm 36$  to  $\pm 72$  VDC @ .5A). Units are supplied with a 5-foot, three-wire cable terminated with a three-pin Molex connector (Part Number [P/N] 19-09-1036; female pins P/N 02-09-1119). The mating connector is Molex P/N 19-09-2036 (with male pins P/N 02-09-2118).

Power input pin designations are:

<b>Pin #</b>	<b>Signal</b>
1 (odd shape)	+Vin (RED)
2	Chassis (EARTH) Ground (WHITE)
3	-Vin (BLACK)

The DC/DC converters isolate input and output so that either polarity DC input can be used. Normally, Pin 2 (Chassis Ground) is connected to one of the two voltage pins. Protection diodes on the converter board prevent damage from input polarity reversal. Fuses are soldered in place to protect the modem from excessive voltage inputs.

The outside case of the DC-powered modems will run warmer to the touch than the corresponding AC-powered units. This is because the cover is used as a heat sink for the DC/DC converter.

## 2.6 Rack Chassis Installation

The 2201 Rack Chassis is designed to accommodate up to ten 2270 modems; see Figure 2-2. The 2201 will fit into a standard 19-inch equipment rack. Tabs are provided on each side of the unit and are predrilled for standard spacing. For further details, refer to the 2201 Rack Chassis / 2200R Redundant Modem Card User Manual.

## 2.7 Mode and Rate Selection

**NOTE: The switch notation standard for mode and rate is the following: Closed = ON, Open = OFF.**

The 2270 has three basic clock operating modes: External, Internal and Slave. These allow the modem, in combination with the Internal Polarity Option jumper, to be configured for a wide range of applications.

Asynchronous operation is accomplished by setting the modem to Internal Mode and oversampling the data (refer to Section 2.7.2, "Internal Clock Operation").

The operating mode is selected by setting positions 4, 5 and 6 of the eight-section switch bank on the front panel. Table 2-A lists the modes and the switch positions. The switch positions are numbered from left to right (1 to 8).

### 2.7.1 External Clock Operation

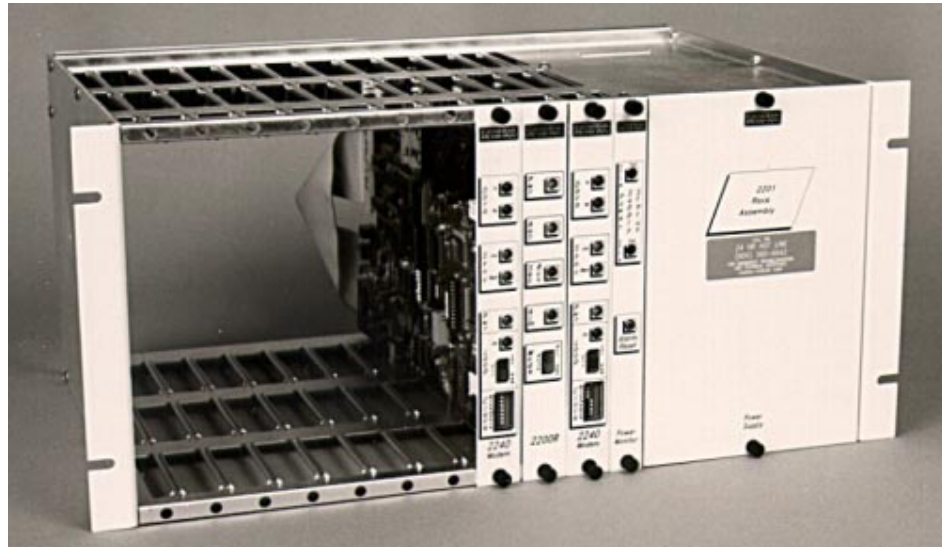
The modem can be set to accept an external clock by closing switch position 4 of the switch block on the front panel. Leaving switch positions 5 and 6 open will ensure that the transmit clock output is clamped.

### 2.7.2 Internal Clock Operation

The modem can be set to provide an oscillator-derived clock to the DTE by closing switch position 6 of the eight-section switch bank on the front panel. Switch position 5 must be left open. Refer to Section 2.7.4 for information on Data Rates. Refer to Section 2.7.7 regarding switch position 4.

**NOTE: For SCT Polarity, refer to Figure 1-3 and Table 1-E; refer to Section 2.7.7 for "Consideration of Propagation Delays."**

**Figure 2-2.**  
**2201 Rack Chassis**  
**Front View**  
**with Modems**  
**Installed**



**Table 2-A. Operating Mode Selections**

Internal SCT Polarity Jumper	DIP Switches (C) Closed (O) Open			Operating Mode
	4	5	6	
NORM	C	O	O	External Clock Mode (SCT suppressed)
NORM	O	C	X	Slave Clock Mode (SCT=Receive Clock) X=DIP switch position 6 is "don't care"
INV	O	C	X	Slave Clock Mode (SCT=Receive Clock Inverted)
NORM	C	C	X	Slave Clock Mode (SCT returned on Ext Clk leads)
NORM	O	O	C	Internal Clock Mode Mode (SCT=Internal Clock)
INV	O	O	C	Internal Clock Mode Mode (SCT=Internal Clock Inverted) DIP switch position 5 must be Open
NORM	C	O	C	Internal Clock Mode Mode (SCT returned on Ext Clk leads)

### 2.7.3 Asynchronous Operation

The 2270 can operate in the data-only asynchronous mode by setting the Clock Mode to INTERNAL and the Clock Rate to the highest frequency setting (switch positions 1-3 all closed).

This allows for a maximum asynchronous rate of one-quarter of the internal clock frequency. For example, if a 2200-C-08 oscillator is used, the maximum frequency is 20 Mbps, and the highest asynchronous data rate would be 5 Mbps. This maximum is based on the assumption that a maximum of 25% peak-to-peak jitter is allowable in the received data signal.

This particular configuration is called "Sampled Asynchronous Transmission." It requires configuring the modem for internal clock and connecting data signals to the normal data input/output pins.

### 2.7.4 Data Rates

The maximum data rate permissible depends on the type of interface used. Only the special high-speed interfaces can be operated above 10 Mbps.

Data rate selection for the 2270 Modem is accomplished by using the front panel switches (see Figure 1-1). Table 2-B provides a data rate table for use in selecting a specific rate in relation to the crystal oscillator factory-installed in the modem. The oscillator frequency is marked on the case of the crystal. Special oscillator frequencies may be requested, if needed.

### 2.7.5 Data Rate vs. Module Frequency

If a high-speed interface is exchanged for a low-speed version, or vice versa, it may be necessary to make an oscillator change on the main modem circuit board. Table 2-B lists the standard oscillators, or you may contact the factory for application assistance.

### 2.7.6 Slave Clock Operation

The slave clock mode may be selected by closing switch position 5 on the front panel eight-section switch bank. This will use the 2270's optical received clock as its transmit clock output. The setting of switch position 6 has no effect. Refer to Section 2.7.7.2 regarding switch position 4.

The System Test feature will function with a modem configured for slave clock operation. However, the user must be aware of the following limitation: If the System Test is enabled, a modem configured for slave clock will provide the System Test timing to the user as receive and transmit clock. This could cause a potential problem, since the System Test timing may not be at the correct data rate for the user device.

A solution to this problem is selecting an oscillator module which allows selecting Internal/Test clock equal to the data rate of the user devices.

**NOTE: The 2270 Modem will not pass data with an external optical loopback when configured for slave clock operation.**

### 2.7.7 Consideration of Propagation Delays

Whenever the modem is sending a transmit clock to the DTE, it is important to understand the effect of the time required for that clock to propagate from the modem to the DTE.

Clock-to-Data phasing is particularly important in any synchronous data link. The modem expects the data to be valid (unchanging) at the point in time when the clock transitions to "clock" the data.

When the modem is the source of the transmit clock, there is a finite time delay before that clock arrives at the DTE to clock its transmitter. There is another time delay before the data from the DTE arrives back at the modem.

Since the modem uses its own clock signal to align the data, there is a potential for these delays to make the data invalid at the point of realignment. This problem only occurs at high data rates and if the cable to the DTE is very long or has high capacitance.

There are two methods used to compensate for this possible misalignment between the clock and data. First, the SCT clock may be inverted (refer to Section 2.7.7.1) or the SCT clock may be returned on the external clock leads (refer to Section 2.7.7.2).

### 2.7.7.1 Clock Polarity Option

The modem supplies clock to the DTE on the SCT interface line. Due to transmission and DTE data delays, this clock may not be properly phased to the transmit data.

If the DTE cannot return this clock back toward the modem on the SCTE or equivalent leads, then the polarity of the SCT clock may be inverted to compensate for the delay.

**Table 2-B. Data Rate Switch Position vs. Oscillator Part Number**

Switch Setting			Oscillator Part Numbers						
			(C) losed	(O) pen	M = megabits	K = kilobits			
1	2	3	2200-C-01	2200-C-02	2200-C-03	2200-C-04	2200-C-05	2200-C-06	
C	C	C	10.752M	12.352M	8.192M	12.624M	6.912M	460.8K	
C	C	O	5.376M	6.176M	4.096M	6.312M	3.456M	230.4K	
C	O	C	2.688M	3.088M	2.048M	3.156M	1.728M	115.2K	
C	O	O	1.344M	1.544M	1.024M	1.578M	864.0K	57.60K	
O	C	C	448.0K	514.7K	341.3K	526.0K	288.0K	19.20K	
O	C	O	224.0K	257.3K	170.7K	263.0K	144.0K	9.600K	
O	O	C	112.0K	128.7K	85.33K	131.5K	72.00K	4.800K	
O	O	O	56.00K	64.33K	42.67K	65.75K	36.00K	2.400K	
OSCILLATOR FREQUENCY			21.504M	24.704M	16.384M	25.248M	13.824M	921.6K	
Switch Setting			2200-C-07	2200-C-08	2200-C-09	2200-C-10	2200-C-11	2200-C-12	2200-C-13
1	2	3							
C	C	C	3.686M	20.00M	6.464M	3.072M	12.928M	115.2K	12.288M
C	C	O	1.843M	10.00M	3.232M	1.536M	6.464M	57.60K	6.144M
C	O	C	921.6K	5.000M	1.616M	768.0K	3.232M	28.80K	3.072M
C	O	O	460.8K	2.500M	808.0K	384.0K	1.616M	14.40K	1.536M
O	C	C	153.6K	833.3K	269.3K	128.0K	538.7K	4.800K	512.0K
O	C	O	76.80K	416.7K	134.6K	64.00K	269.3K	2.400K	256.0K
O	O	C	38.40K	208.3K	67.33K	32.00K	134.7K	1.200K	128.0K
O	O	O	19.20K	104.2K	33.67K	16.00K	67.33K	0.600K	64.0K
OSCILLATOR FREQUENCY			7.373M	40.00M	12.928M	6.144M	25.856M	230.4K	24.576M

To accomplish this, the SCT POL jumper needs to be changed. The position set at the factory is NORM, which assumes a negligible delay in the cable and DTE user device. The INV position can improve performance if that delay is an odd-multiple of one-half a clock period. Using an oscilloscope, the SCT and TXDA-lead waveforms can be examined to confirm that the falling edge of the clock *does not* occur close to the changes in TXD. If this edge is too close to the data transitions, the INV position must be used.

**NOTE: This will not change the SCT to TXD phase relationship viewed on the interface, but will compensate for the phasing problem.**

#### 2.7.7.2 SCT Returned On External Clock Leads

If the DTE is capable of returning the transmit clock (supplied by the modem) back to the modem on the SCTE leads as an external transmit clock, better clock data phasing can be achieved at the transmitter.

This can result in a significant improvement at higher data rates. Close switch position 4 on the front panel for the modem to use the incoming clock for the transmitter and check the cables to be sure they support SCTE.

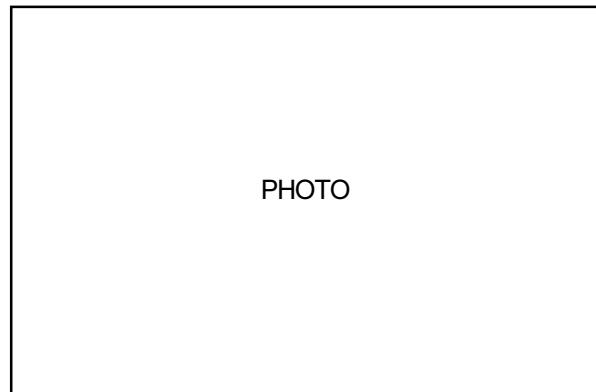
## Chapter 3 - Data Interfaces

---

### 3.1 Electrical Data Interfaces

A variety of interfaces are available with the 2270 Modem. Each is designed to conform with existing standards. Refer to Section 7, "Specifications," for applicable configurations, standards and physical connector types.

**Figure 3-1.**  
**2270**  
**Interchangeable**  
**Interfaces**



### 3.2 RS-232C/423 Interface Model -32

This interface is electrically compatible with EIA RS-423A. It will also operate with RS-232C systems when adhering to the more limiting RS-232C specifications (50-foot distance and 20-kbps data rate). EIA standard RS-423 does not reference physical connector type or pinouts. This RS-423 interface uses the physical connector type and pinouts specified in RS-232C (refer to Table 3-A).

The RS-232C/423 interface uses a 25-pin female D-type connector for the physical connection.

**NOTE: The control leads support only a local handshake.**

### 3.3 RS-449/422 Interfaces

The RS-449/422 interface is available in several models to suit a wide range of user requirements. Table 3-B lists the standard models.

This interface is compatible with EIA Standard RS-449. It uses a standard 37-position, female D-type connector (DC-37). Pin assignments for each of the models are outlined in Table 3-C.

Only a local handshake is supported for the control leads. The maximum data rate specified is 10 Mbps.

**Table 3-A. RS-232C/423 Signals and Pin Assignments**

RS-232C		signal name	RS-423/CCITT		signal direction
pin	mnem			mnem	
1	FG	Frame Ground	FG	101	n.a.
2	TXD	Transmit Data	SD	103	to modem
3	RXD	Receive Data	RD	104	from modem
4	RTS <sup>1</sup>	Request To Send	RS	105	to modem
5	CTS <sup>1</sup>	Clear To Send	CS	106	from modem
6	DSR	Data Set Ready	DM	107	from modem
7	SG	Signal Ground	SG	102	signal ground
8	DCD <sup>1</sup>	Data Carrier Detect	RR	109	from modem
11 <sup>2</sup>	LT	Local Loopback Test			to modem
15	SCT	Serial Clock Transmit	ST	114	from modem
17	SCR	Serial Clock Receive	RT	115	from modem
18 <sup>2</sup>	RT	Remote System Test			to modem
24	SCTE	Tx External Clock	TT	113	to modem

1 - Only Local Handshake is supported  
 2 - The 2270 Modem includes a built-in Loopback Test feature. Two normally undefined lines (RS-232C pins 11 and 18) are used for interface control of these system test functions. Refer to Chapter 5, "Troubleshooting," for a more thorough description of this feature.

**Table 3-B. Available Models of RS-449/422 Interfaces**

Model	Description
-22	RS-449/422 (RS low)
-H22	RS-449/422 (RS high)
-R2R	RS-449/422 (balanced CTS, RS low)



**Table 3-C. RS-499 (RS-422) Signals and Pin Assignments**

pin	EIA	signal name	CCITT	signal direction
1	FG	Frame Ground	101	frame ground
19	SG	Signal Ground	102	signal ground
4/22	SD	Send Data	103	to modem
5/23	ST/SCT	Send Timing	114	from modem
6/24	RD	Receive Data	104	from modem
7/25	RS/RTS (b,c,d,e)	Request To Send	105	to modem
8/26	RT/SCR	Receive Timing	115	from modem
9/27	CS/CTS (d,e)	Clear To Send	106	from modem
10	LL/LT (a)	Local Loopback Test	141	to modem
13/31	RR/DCD (e)	Receiver Ready / Data Carrier Detect	109	from modem
14	RL/RT (a)	Remote System Test	140	to modem
17/35	TT/SCTE	Terminal Timing	113	to modem
11/29	DM/DSR	Data Mode/Data Set Ready	107	

a. The 2270 Modem includes a built-in Loopback Test feature. Two normal test lines (RS-422 pins 10 and 14) are used for this interface loop. Refer to Chapter 5, "Troubleshooting," for a more thorough description of this feature.

b. Model -22: Request To Send is held low when there is no connection or the interface connection is removed.

c. Model -H22: Request To Send is held high when the user's device does not supply an RS input or the interface connection is removed.

d. Model -R2R: Request To Send is held low as with the -22. Clear To Send is provided as a balanced output.

e. Only local handshake is supported.

### 3.3.1 Model -22

The RS input control is biased to the OFF (negative voltage) state. If a connection is not made to this line, the CS control output from the modem will drive to the OFF state.

### 3.3.2 Model -H22

The specific difference between the -H22 model and the standard -22 model is that the RS input control is biased to the ON (positive voltage) state. If a connection is not made to this line, the CS control output from the modem will drive to the ON state.

### 3.3.3 Model -R2R

The RS input control is biased to the OFF (negative voltage) state. If a connection is not made to this line, the CS control output from the modem will drive to the OFF state.

This interface provides the Clear to Send (CS) control as balanced output (using two leads).

### 3.4 RS-530 Interface Model -R30

The EIA RS-530 interface uses RS-422 (balanced) electrical signals for all interface circuits (data, clock and control), except for the loopback (local/remote), and test mode pins which use RS-423 (unbalanced bipolar) electrical signals. The DB-25 pin assignments and signals supported are detailed in Table 3-D. Jumper options are detailed in Table 3-E.

Normally, the control leads RTS, CTS, DSR and TM are supported locally (i.e., no end-to-end connectivity). RTS can be used to control DCD at the far-end if the 2270 is set for flow control.

**NOTE: DTR to RI is not supported on the 2270.**

A 3.5 mm stereo phone jack is provided for an alarm contact output for 2270 applications. This contact is controlled by the presence of CD (Optical Receive Carrier Detect). If CD is not valid or power is lost, the relay is in the alarm state. A jumper (RLY) controls the selection of either the open or closed state. This is a three-contact jack. The alarm circuit is present between the tip and sleeve contacts. The contact rating is 24VAC or 24VDC at 0.5A.

**Table 3-D. RS-530 Signals and Pin Assignments**

Pin	#	Signal Name	Direction
FG	01	Frame Ground	-
TD	02/14	Transmit Data	to modem
RD	03/16	Receive Data	from modem
RTS	04/19	Request to Send	to modem
CTS	05/13	Clear to Send	from modem
DSR	06/22	Data Set Ready	from modem
SG	07	Signal Ground	-
DCD	08/10	Data Carrier Detect	from modem
SCR	17/09	Receive Clock	from modem
SCT	15/12	Transmit Clock	from modem
SCTE	24/11	External Tx Clock	to modem
DTR	20/23	Data Terminal Ready	to modem
LL	18*	Local Loopback	Loopback
RL	21*	Remote Loopback	Loopback
TM	25	Test Mode	from modem

\* These signals are single ended and activate a modem's system test. All other signals are balanced.

"Cross-over" Cable for a CP to "standalone" CP fiber modem connection  
(Used when another f/o IFL is needed to extend the current link)

Signal	Tip/Ring	to	Tip/Ring	Signal
TD	2/14		3/16	RD
RD	3/16		2/14	TD
TC	24/11		17/9	RC
RC	17/9		24/11	TC

Table 3-E. RS-530 Jumper Options

<b>Jumper Options</b>	
<b>W2</b>	<p><b>CHASSIS GND Jumper (*)</b>            100 Ohm position: Connects chassis ground to signal ground through 100 ohm resistor.            SHORT position: Connects chassis ground directly to signal ground.  <b>Factory Setting = 100 OHM</b></p>
<b>W??</b>	<p><b>RLY Jumper</b>            NC position: CD (Carrier Detect) alarm relay contact closes on alarm condition or power loss.            NO position: Opposite state of relay contact.  <b>Factory Setting = NC</b></p>
<b>W16</b>	<p><b>DSR Jumper</b>            TEST position: DSR (Data Set Ready) is asserted whenever a Test or Loopback condition is not present.            EIA: DSR is asserted in Test or Loopback condition only if testing is being conducted through the interface.  <b>Factory Setting = TEST</b></p>
<b>W??</b>	<p><b>CTS GATE Jumper</b>            ON position: CTS (Clear to Send) is asserted after a delay from RTS (Request to Send).            CD position: CTS also needs the presence of the valid optical receive Carrier Detect (CD)  <b>Factory Setting = ON</b></p>
<b>W17</b>	<p><b>RTS BIAS Jumper</b>            OFF position: RTS (Request to Send) input is detected as an OFF (negated) condition if input signal is not provided.            ON position: ON (asserted) state of RTS if input signal is not provided.  <b>Factory Setting = OFF</b></p>
<b>W??</b>	<p><b>CTS Out Jumper</b>            CTS    CTS Output = Local CTS function (see also CTS GATE Jumper above)            (Must be set to CTS on 2270, RI not supported.)  <b>Factory Setting = CTS</b></p>
	<p>* If modem has a jumper to connect Chassis Ground and Signal Ground, it must be left in the OPEN or FLOAT position for interface jumpers to work correctly.</p>

### 3.5 T1/E1 Interfaces

There are only two versions of T1/E1 interfaces available. The Transparent Bipolar models -B1, B2 and B3 are compatible with any bipolar line coded T1/E1 data and the DS1/T1 Model -T1 is for T1 only.

#### 3.5.1 Transparent Bipolar Models -B1, -B2, -B3

This interface is compatible with any bipolar line coded T1/E1 data (1.544 Mbps/2.048 Mbps). All types of codes, including AMI, B8ZS, B7S or HDB3, will be accurately transmitted/received (refer to Table 3-F). Line Build Out settings for T1 are given in Table 3-G.

**NOTE: Do not use the first switch setting for T1. It is reserved for E1 only.**

**NOTE: This interface passes all bipolar violations without correction. If AMI/T1 coding is used, and correction is desired, the DS1/T1 interface must be used.**

**NOTE: This interface is not compatible with any other type of interface. If compatibility with either DS1/T1 interfaces or clock and data interfaces is necessary, the DS1/T1 must be used.**

There are three different types of interface connectors indicated by the number at the end of the interface code. The connectors are female DA-15 (B1); a four-position terminal block (B2); or two female BNC (B3). Figure 3-2 shows how the input and output pairs are wired to these connectors.

This interface performs jitter attenuation of the transmit line input signal. It is also designed to propagate an all "1's" AMI stream if the end-to-end line is interrupted.

**NOTE: When using this interface, the modem must be configured for external clock.**

*Table 3-F. Transparent Bipolar Line Interfaces*

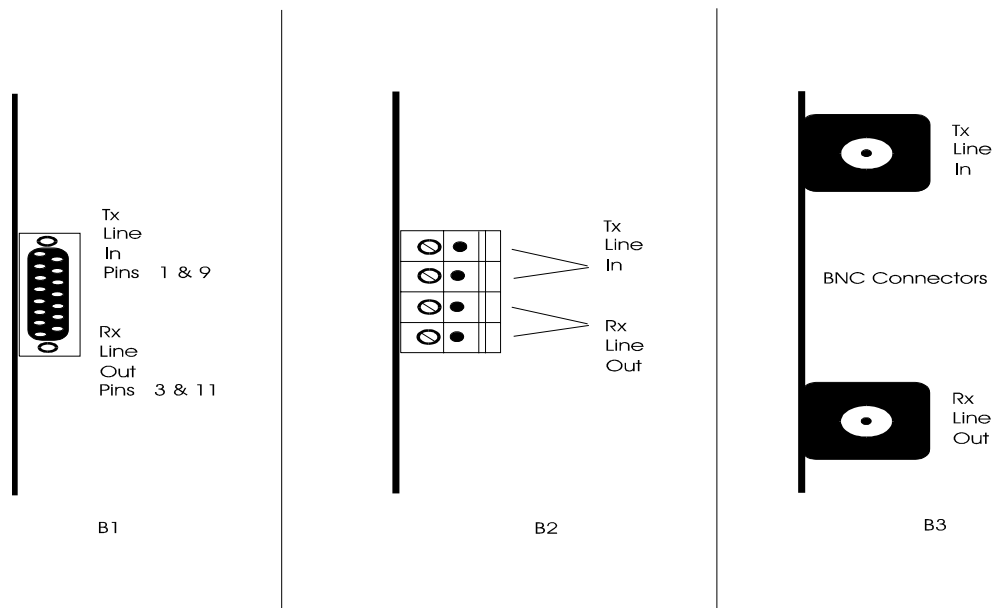
<b>Model #</b>	<b>Interface Connector Type</b>	<b>Speed</b>
B1	DA 15	1.544 Mhz T1 or 2.048 MHz E1
B2	Terminal Block	1.544 Mhz T1 or 2.048 Mhz E1
B3	BNC	1.544 Mhz T1 or 2.048 Mhz E1

**Table 3-G. Line Build Out Settings**

	Switch Positions for 4Bx					
	1	2	3	4	5	MODE OF OPERATION
	E1	T1	LEN0	LEN2	LEN1	
E1	ON	OFF	ON	ON	ON	E1 CCITT
DSX-1 ABAM & PIC	OFF	ON	OFF	ON	OFF	0-133 FT
	OFF	ON	ON	OFF	ON	133-266 FT
	OFF	ON	OFF	OFF	ON	266-399 FT
	OFF	ON	ON	OFF	OFF	399-533 FT
	OFF	ON	OFF	OFF	OFF	533-655 FT
CSU	OFF	ON	ON	ON	OFF	PART 68 OPT. A
	OFF	ON	OFF	ON	OFF	T1C1.2

These interfaces are fully transparent to line codes such as B8ZS or HDB3. Three DIP switches (3, 4 and 5) are provided for selecting various line buildout settings. Standard factory settings are T1 at 0-133 feet for all three models. Two DIP switches (1 and 2) are provided to select CCITT speed (2.048 Mhz X 3) or T1 speed (1.544 Mhz X 3).

**Figure 3-2.  
Transparent  
Bipolar Interface  
Connectors**



### 3.5.2 DS1 / T1 Model -T1

This interface is compatible with AMI-coded T1 data only. If line coding is other than AMI, such as B8ZS, then a model B type interface must be used.

**NOTE: This interface corrects bipolar violations. If these violations must pass through for fault detection, a model B type interface must be used.**

**NOTE: This interface is compatible with clock and data transmission. The other end of the link can have a variety of interfaces (e.g., -32, -22, -35, etc.), if required.**

A special four-position feed-through terminal block is provided for connecting the T1 twisted pairs to the 2270 modem. The standalone version has the terminal positions marked on the rear of the unit.

The DS1/T1 rack-mount versions do not have any external indication as to which pair should be connected to which terminals; however, these positions are indicated on the circuit board. When viewing the 2201 Rack Chassis from the rear, the upper two terminals are for the transmit pair and the lower two are for the receive pair.

The T1 interface wires are secured by inserting them into the square aperture under the terminal screw. Tightening the terminal screw, clamps the wire in position.

An access hole for a diagnostic probe is provided above the clamping screw.

**NOTE: When using the DS1/T1 interface, the modem must be configured for external clock.**

## 3.6 TTL/BNC Interface Model -BN

This model uses BNC (bayonet) connectors for the physical interface. The electrical signal characteristics are unbalanced TTL levels, with only the clock and data circuits supported. Four BNC connectors are supplied for connection to a DTE device.

High speeds and long distances (clock and data only) can be achieved using this interface.

This interface version has a switchable dual purpose port for the Send Timing (SCT) and Terminal Timing (SCTE) clock signals. A two-position slide switch (S1) on the interface card controls the port direction.

When the switch is set towards the BNC connectors, the port is configured as an input (for the SCTE clock). Sliding the switch away from the BNC connectors configures the port as an output (for the SCT clock). (See Figure 3-6 for connectors and refer to Table 3-K for signals supported.)

**NOTE: When setting up the clock select, the proper main circuit board clock mode must be set correctly, i.e., external for the SCTE clock input, slave or internal for the SCT clock output.**

### 3.7 CCITT V.35 Interface Model -35

This interface is compatible with CCITT recommendation V.35 Appendix II (electrical characteristics for balanced double-current interchange circuits).

The RTS control input is biased to the OFF state. If a connection is not made to this line, the CTS control output will drive to the OFF (negative voltage) state. Recommended cable is a twisted multi-pair type with a characteristic impedance of 80-120 ohms at the operating data rate. The balanced line receivers are terminated at 100 ohms.

The V.35 interface uses a standard 34-position, M-series (MRAC-34S) Winchester connector. The terminal or computer interface must be configured as Data Terminal Equipment (DTE) for proper communications handshake (refer to Table 3-H for pinouts).

**NOTE: Only local controls are supported.**

*Table 3-H. CCITT V.35 Digital Interface and Pin Assignments*

pin a/b	mnem	signal name	CCITT	signal direction
A	FG	Frame Ground	101	n.a.
B	SG	Signal Ground	102	n.a.
C	RTS	Request To Send	105	to modem
D	CTS	Clear To Send	106	from modem
E	DSR	Data Set Ready	107	from modem
F	DCD	Data Carrier Detect	109	from modem
R/T	RXD	Receive Data	104	from modem
V/X	SCR	Serial Clock Receive	115	from modem
Y/AA	SCT	Serial Clock Transmit	114	from modem
P/S	TXD	Transmit Data	103	to modem
U/W	SCTE	External Transmit Clock	113	to modem
CC (*)	RL/RT	Remote System Test	140	to modem
HH (*)	LL/LT	Local Loopback Test	142	to modem

n.a. = not applicable  
 (\*) = The 2270 Modem includes a built-in System Test feature. Two normal test lines (CCITT V.35 pins CC and HH) are used for this interface loop. Refer to Chapter 5, "Troubleshooting," for a more thorough description of this feature.

### 3.8 Programmable Buffered Interface – Model P53

The Model P53 Interface Module employs an RS-422 electrical interface with a DB-25 interface connector (RS-530). It also employs an 8-bit elastic buffer.

A combination of FIFO (First In, First Out), Delay Line and Inverter circuitry allows you to customize the configuration for a variety of standard and nonstandard synchronous clocking arrangements.

Interface configuration is accomplished via an on-card wire wrap header (J3) and a four-position DIP switch. This interface offers flexible control configurations as well as clock and data. The standard configuration for this interface is DCE with DB-25S connector. Two connector adapters are provided with each interface. The DCE/DTE adapter converts the physical interface to DTE with DB-25P. The "Legacy" adapter converts the interface from DCE to the pinout of the original "P2" interface product.

Figure 3-3 illustrates the resources available for configuring via the J3 wire wrap header. A wide variety of configurations are possible to satisfy many requirements.

This interface is typically used to interface with encryption devices on the BLACK side where the modems act as the network and supply clocking in a synchronous configuration, or to interface to the RED (clear) side of data encryption (KG) equipment. In the RED application, the interface acts as a "tail-circuit adapter" device. This configuration allows the modem to accept two synchronous clock (typically, DCE devices only accept one): one for transmit (external clock) and one for receive (FIFO input clock).

Another common application is with systems that communicate over geosynchronous satellites. In this application, the FIFO is used to make up for clock drift (doppler shift) caused by the satellite's elliptical orbit around the Earth.

Figure 3-4 illustrates the location of the J3 programming header, the DIP switches used for setting the delay line parameter, the interface connectors, the KG Resync control output setting jumpers and all factory default jumper settings.

The FIFO allows the user to recondition either the received or transmitted data (not both). The Delay Line, in conjunction with a four-position DIP switch, provides an option for fine-tuning the relationship between clock and data timing. Table 3-1 defines the delay times versus switch settings for Model P53.



PROGRAMMABLE BUFFERED INTERFACE  
MODEL P53, DCE RS-530

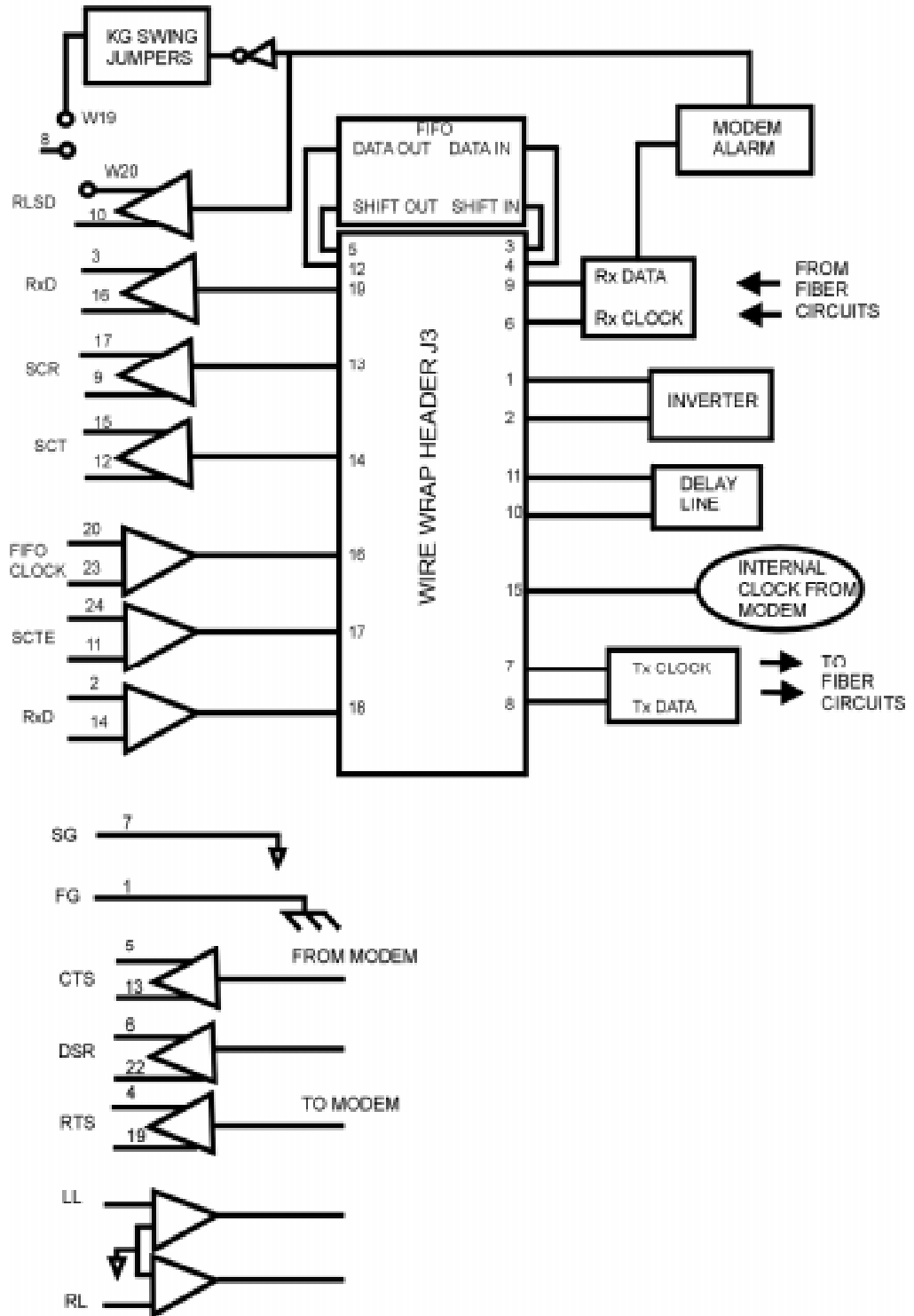


Figure 3-3.  
Available  
Strapping Options  
for Programmable  
Buffered Interface

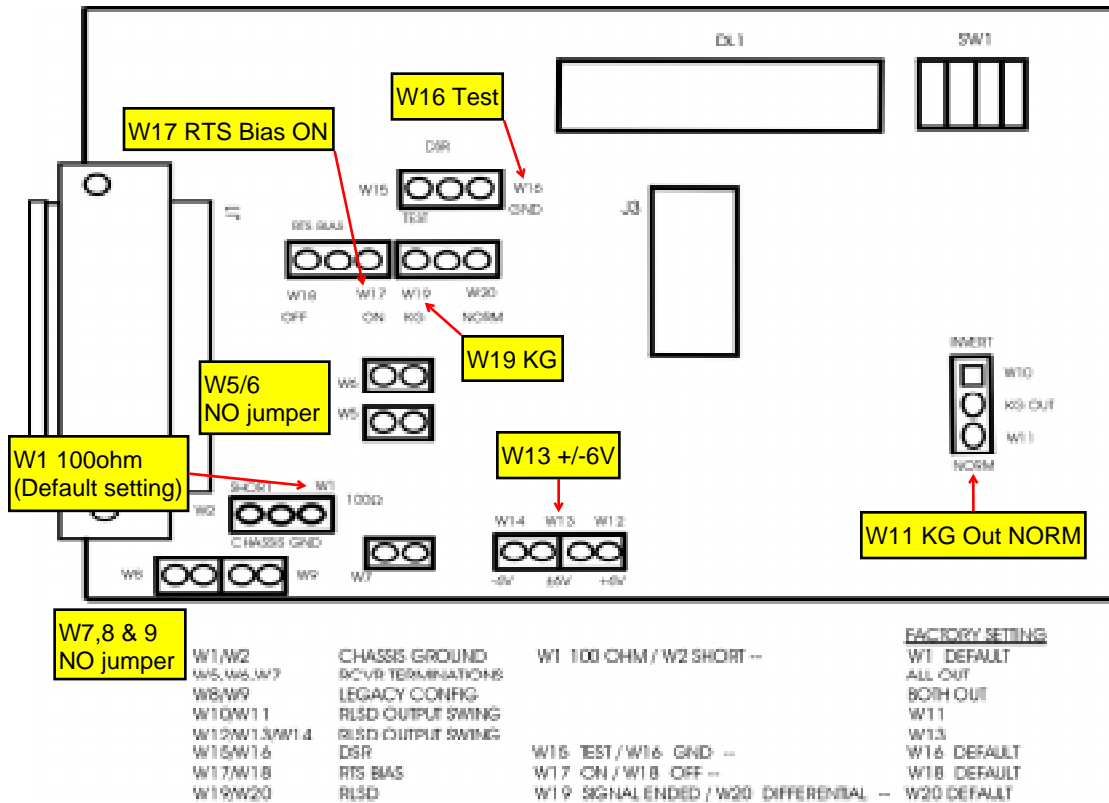


Figure 3-4. Board Layout for Programmable Buffered Interface

Table 3-1. Delay Times for Programmable Buffered Interface

SW1 Position (O)pen (C)losed				Delay Time P53
1	2	3	4	
C	C	C	C	20 ns
O	C	C	C	30 ns
C	O	C	C	40 ns
O	O	C	C	50 ns
C	C	O	C	60 ns
O	C	O	C	70 ns
C	O	O	C	80 ns
O	O	O	C	90 ns
C	C	C	O	100 ns
O	C	C	O	110 ns
C	O	C	O	120 ns
O	O	C	O	130 ns
C	C	O	O	140 ns
O	C	O	O	150 ns
C	O	O	O	160 ns
O	O	O	O	170 ns

This interface has strap option jumpers to configure the RLSD Output at J1-8/10 (DB-25) to support the KG-194 Resync functionality. Jumper straps W10/W11 (adjacent to U11) and W12/W13/W14 (adjacent to U8) implement this function (refer to Table 3-J). Jumper straps W10/W11 control the ON/OFF level and W12/W13/W14 configure the RLSD Output to Bipolar (+6 V and -6 V) or single-ended (+6 and 0 or -6 and 0).

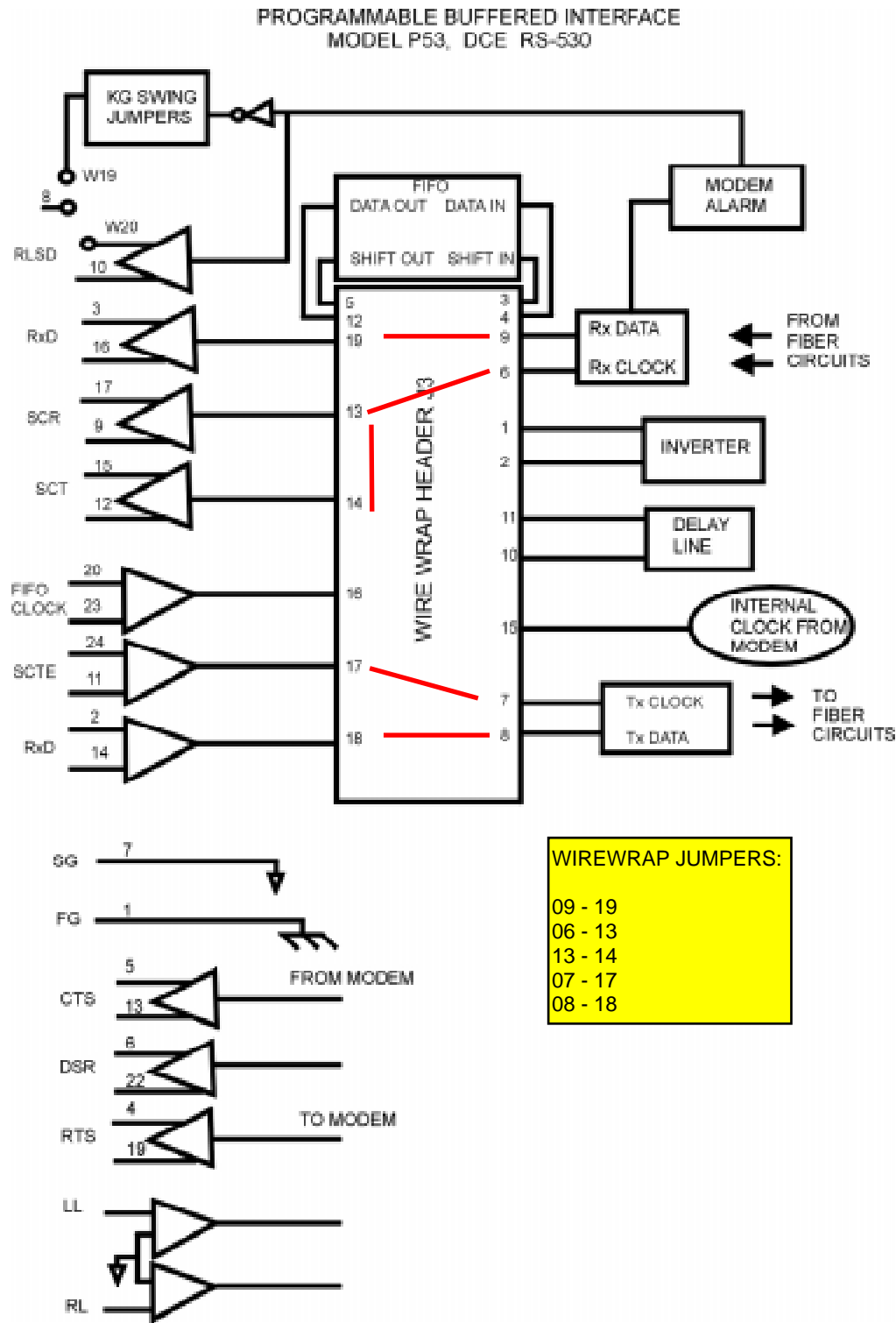
The W1/W1 strap connects chassis ground to signal ground (W2 position), connects chassis ground through 100 ohms to signal ground (W1 position), or isolates chassis ground from signal ground (jumper out). The W5, W6 and W7 jumpers, when installed, ground the midpoints of the 100 ohm termination resistances of the FIFOCLK, SCTE and TxD line receivers. These jumpers may provide improved performance in cases where the RS-422 inputs are bipolar rather than the more common unipolar types. The W8, W9 and W15/W16 jumpers are used for converting to the Legacy configuration (see Figure 3-10).

**Table 3-J. Strap Configurations for Programmable Buffered Interface**

STRAP CONFIGURATIONS	CD OUTPUT (AT J1-6) VOLTAGE LEVEL $\pm 1$ V ON/OFF
W11 and W14	+6/-6
W11 and W12	+6/0
W11 and W13	0/-6
W10 and W14	-6/+6
W10 and W12	0/+6
W10 and W13	-6/0

### 3.8.1 Generic Interface

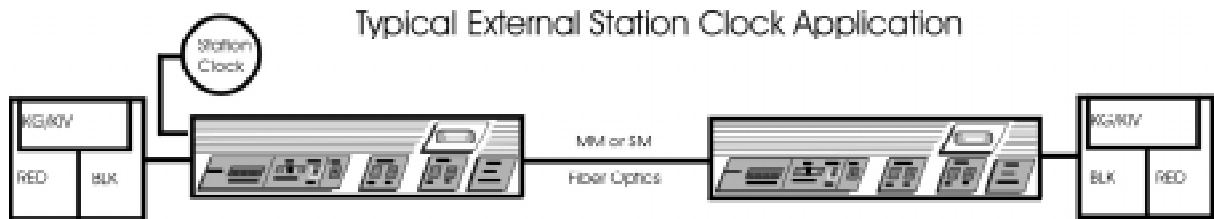
This interface (see Figure 3-5) conforms to the EIA RS-530 pinout and signal flow for a DCE device.



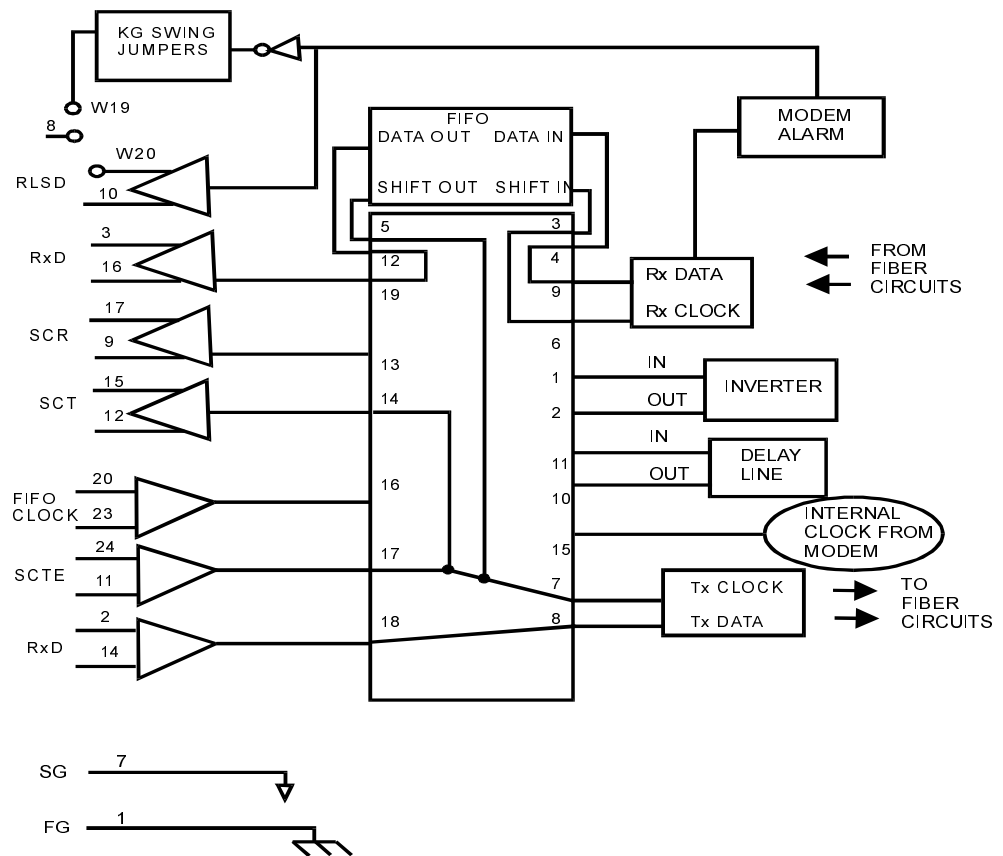
*Figure 3-5.  
Programmable  
Buffered Interface,  
Model P53, **DCE**  
RS-530*

### 3.8.2 External Station

The External Station is used when an external station clock is providing timing (see Figure 3-6). When connecting KG or KIV encryptors together on the Black side, using an external timing device you should install the external station clock strapped header in the J3 position. In this application, the modems are acting as the network, although the timing input is from an outside source. The modem in which the timing source is connected should be set for external and the other modem set for slave. This header is provided with the interface.



EXTERNAL STATION  
PROGRAMMABLE BUFFERED INTERFACE  
MODEL P53, DCE RS-530



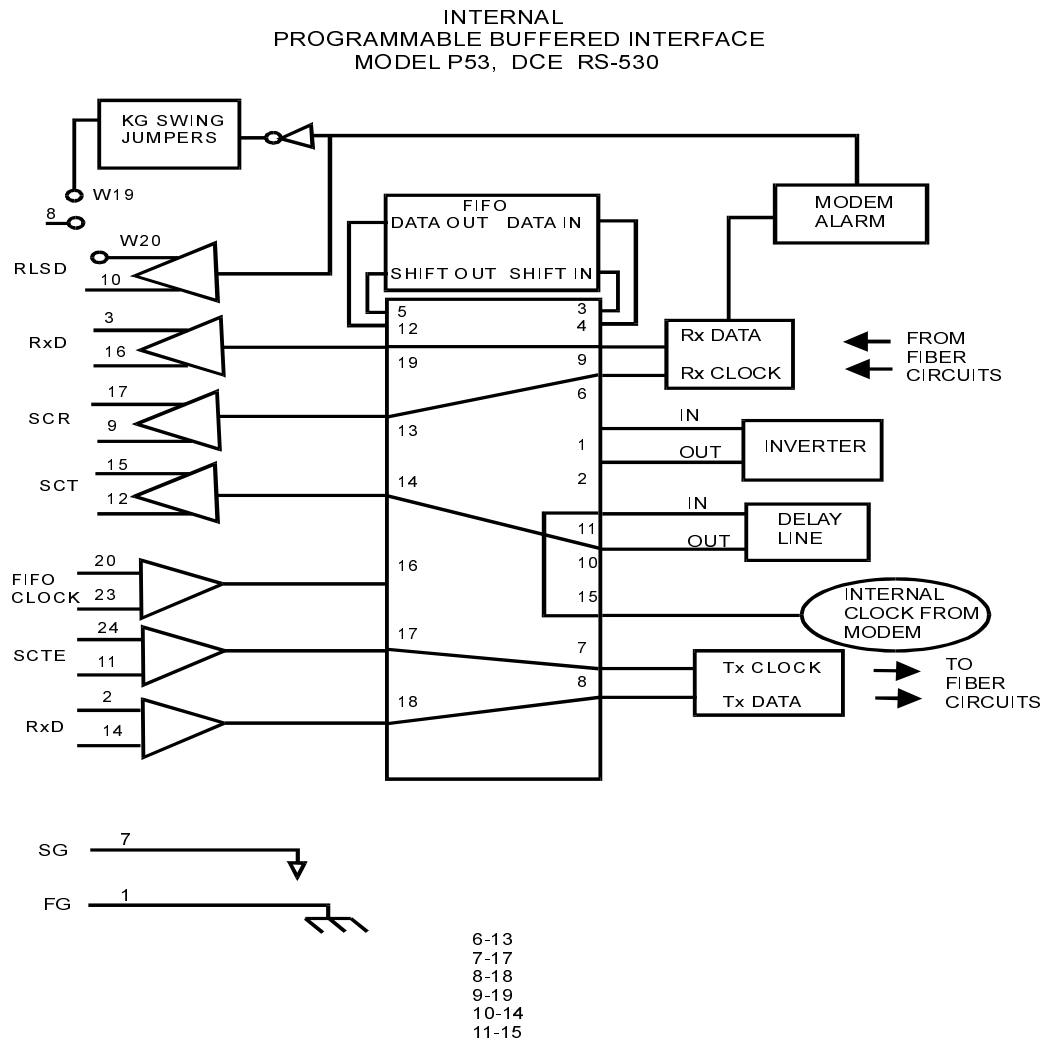
**Figure 3-6.**  
**Programmable**  
**Buffered Interface,**  
**Model P53, Exter-**  
**nal Station**

3-6  
4-9  
5-7  
7-17 & 14  
8-18  
12-19

### 3.8.3 Internal

The internal function is used when network equipment is set for Eternal Timing (see Figure 3-7). When connecting KG or KIV encryptors together on the Black side, you should install the internal strapped header in the J3 position. In this application, the modems are acting as the network timing source. In most cases, both modems should be set for internal master clock. The rate switches should be set to the appropriate speed for the circuit. This header is provided with the interface.

#### Typical Internal Clock Application



**Figure 3-7.**  
**Internal Programmable Buffered Interface, Model P53, DCE RS-530**

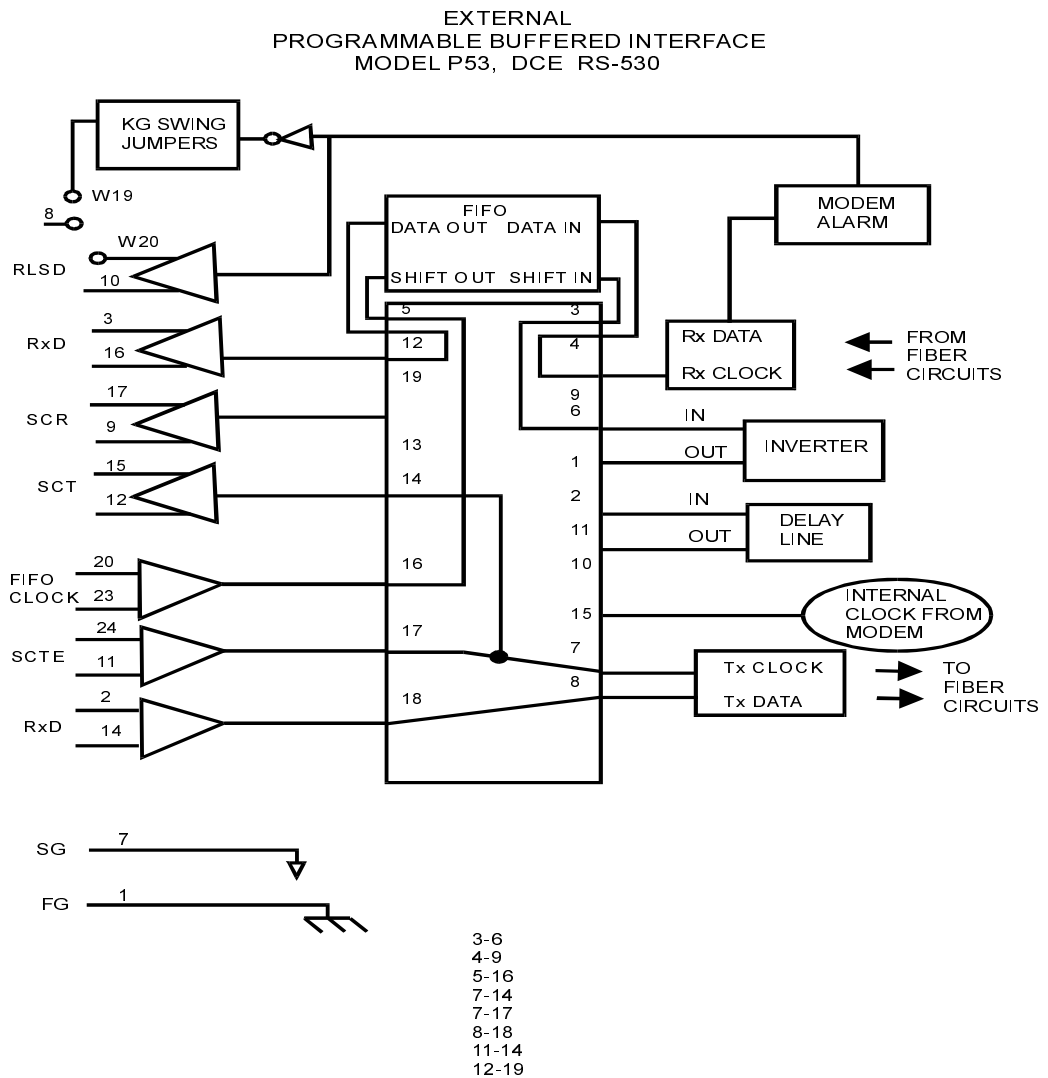
### 3.8.4 External

The External function is used when network equipment is set for Network or Internal Timing (see Figure 3-8). When connecting KG or KIV encryptors on the Red side to a DTE device, you should install the external strapped header in the J3 position. In this application, the modems are acting as an extension of the Red side cable in a true tail circuit. The modem at the Red end is set for external clock and the modem at the DTE end is set for slave clock. This header is provided with the interface.

Typical External Clock Tail Circuit Application

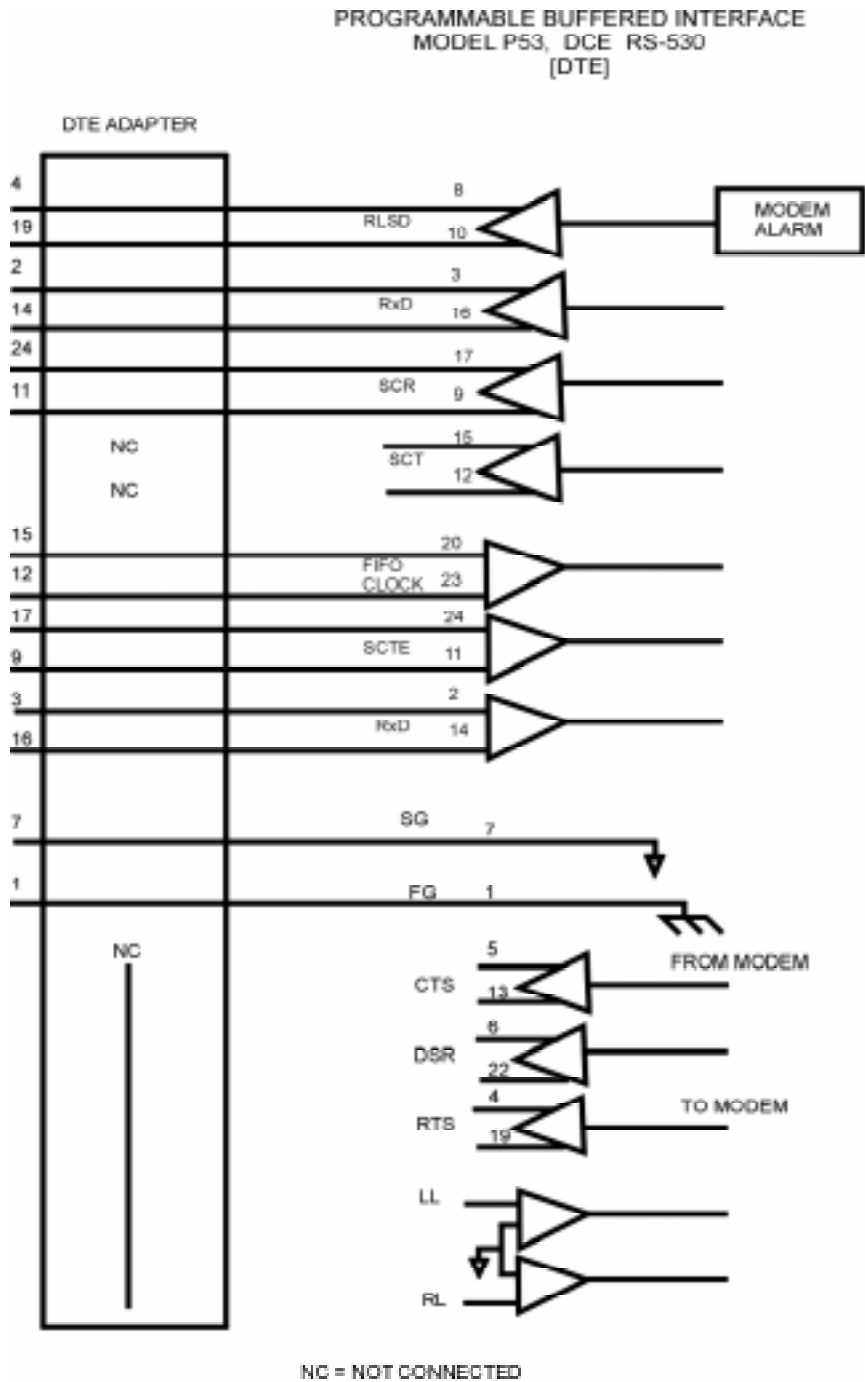


Figure 3-8. External Programmable Buffered Interface, Model P53



### 3.8.5 DTE Adapter

This adapter is supplied with the P53 interface and should be used when connecting to a DCE device. This allows the use of a straight-through RS-530 cable. Figure 3-9 illustrates the DCE to DTE pin assignments. The gender of this adapter on the user side is male.



**Figure 3-9.  
Programmable  
Buffered Interface,  
Model P53  
[DTE]**



### 3.8.6 Legacy Adapter

This adapter is provided with the P53 interface and should be used if preexisting cabling was installed for use with Model P2 interface cards (see Figure 3-10). This adapter converts the standard RS-530 pin assignment on the P53 back to the original P2 pin assignments.

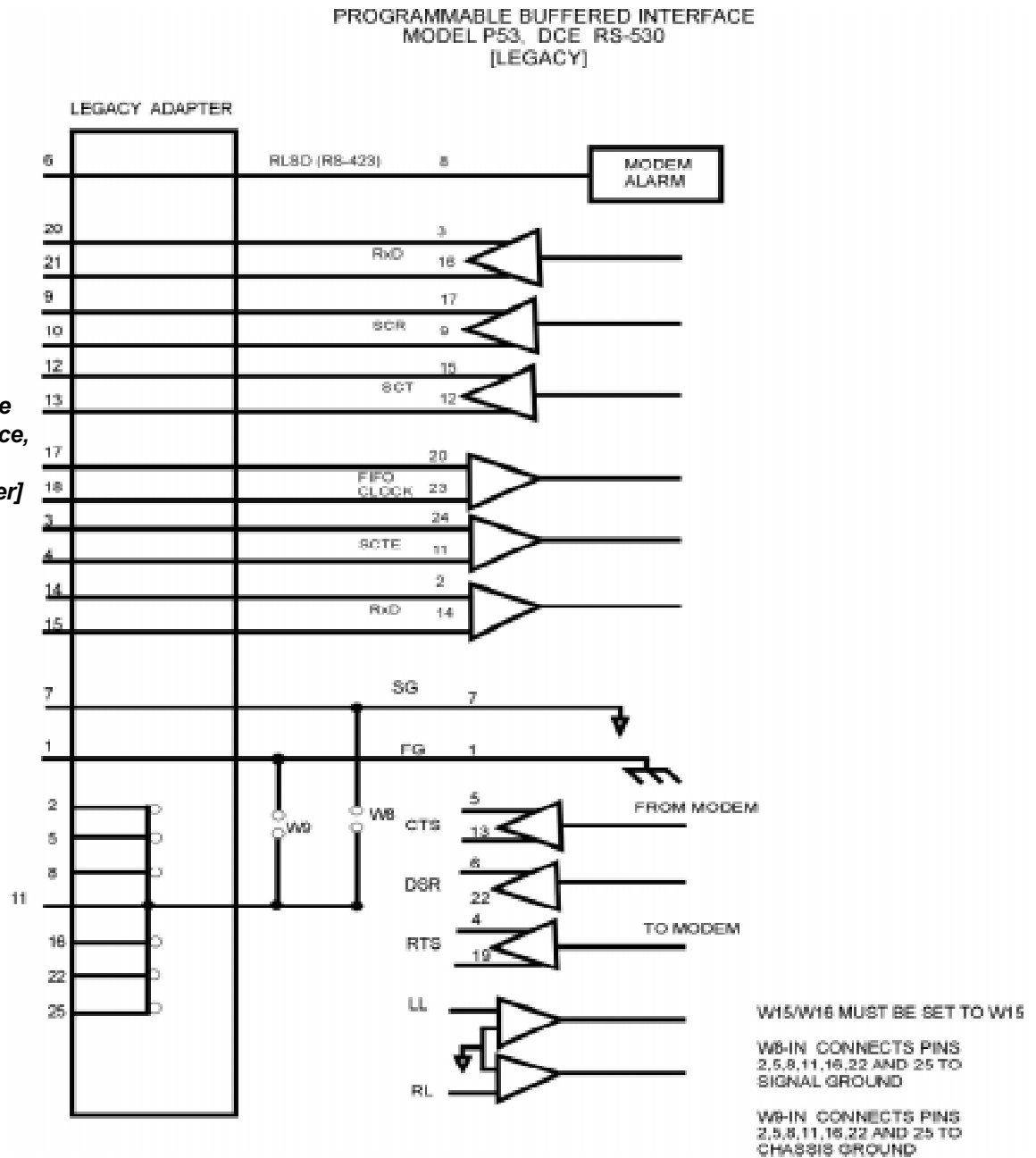


Figure 3-10.  
Programmable  
Buffered Interface,  
Model P53  
[Legacy Adapter]

### 3.9 High-Speed RS-422/Mil-Std 188-114C Interfaces

There are three High-Speed RS-422 interface models (-TW, -T22 and -D22) and three High-Speed Mil-Std 188-114C interface models (-TW8, -T88 and -D88) available.

All can operate up to 20 Mbps. All support only clock and data signals as shown in Table 3-K. Both the RS-422A and Mil-Std 188-114C are balanced differential electrical signals.

The RS-422A operates between +1 and +4 volts whereas the Mil-Std 188-114C swings between  $\pm 3$  volts. The termination impedances vary slightly as illustrated in Table 3-L. The two interface types will communicate with each other but center tap ground jumpers E2 and E3 must be removed from a Mil-Std 188-114C interface (refer to Table 3-M).

The basic differences between the models is the type of physical connectors used for the interface. Table 3-L lists the six interface models with the corresponding source and termination impedances and physical connectors. Table 3-M shows the jumper options available and the factory default settings for the jumpers.

**Table 3-K. TwinAx and BNC Supported Signals**

Signal	Full Name	Direction
TxD	Transmit Data	To Modem
RxD	Receive Data	From Modem
SCR	Serial Clock Receive	From Modem
SCT	Serial Clock Transmit	From Modem
SCTE	External Clock Transmit	To Modem

**Table 3-L. Model Characteristics**

Model	Electrical Interface Type	Physical Interface Type	Driver Impedance Figure / Table	Driver Impedance	Termination Impedance
TW	RS-422A	4 TwinAx	Fig. 3-6	<100 Ohms	100 Ohms $\pm 10\%$
TW8	Mil-Std 118-114C	4 TwinAx	Fig. 3-6	<100 Ohms	78 Ohms $\pm 10\%$
T22	RS-422A	5 TwinAx	Fig. 3-7	<100 Ohms	100 Ohms $\pm 10\%$
T88	Mil-Std 188-114C	5 TwinAx	Fig. 3-7	<100 Ohms	78 Ohms $\pm 10\%$
D22	RS-422A	DC-37	Tbl. 3-N	<100 Ohms	100 Ohms $\pm 10\%$
D88	Mil-Std 188-114C	DC-37	Tbl. 3-N	<100 Ohms	124 Ohms $\pm 10\%$

**Table 3-M. Jumper Strap Options**

JUMPER ID	DESCRIPTION	FACTORY CONFIGURATION					
		TW	TW8	T22	T88	D22	D88
W1/W2	Defines whether alarm relay contact is normally open (W2) or normally closed (W1)	W2	W2	N/A	N/A	N/A	N/A
W3/W4*	W3=VCO disabled W4=VCO enabled	W4	W4	W4	W4	W4	W4
W5/W6	W6=Normal SCT W5=Inverted SCT	W6	W6	W6	W6	W6	W6
W7/W8	W7=Shield connected to W7 chassis ground W8=Shield connected to signal ground	W7	W7	W7	W7	W7	W7
W9/W10	W9=Chassis ground connected to signal ground W10=Not connected	W10	W10	W10	W10	W10	W10
E2	TxD RCV termination resistor center tap to shield ground	N/A	I N	N/A	I N	N/A	I N
E3	SCTE RCV termination resistor center tap to shield ground	N/A	I N	N/A	I N	N/A	I N

\* W3/W4 jumper option may not exist on some older versions. It is only required when performing Local loopbacks. The W4 position corrects the duty cycle of External Clock above 9 Mbps.

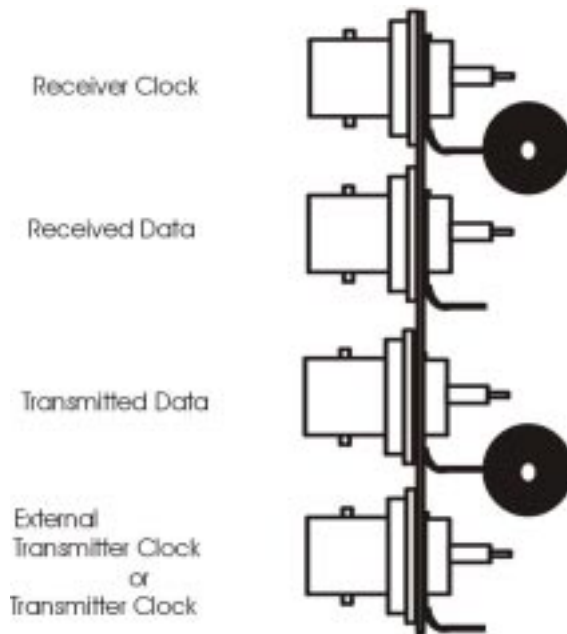
### 3.9.1 Model -TW

The signaling used on this interface is RS-422A. Four TwinAx connectors (BJ-77 type) are used for the physical connection (see Figure 3-11).

A switch is provided to select whether the fourth TwinAx (SCT/SCTE) is to be used as an output (SCT) or as an input (SCTE). By setting the switch to the SCT position, the port becomes an output providing the clock to the connected device. When set for SCTE, the port becomes an input and will accept a clock from the connected device.

SCT should be selected if the modem is set for Internal or Slave Clock mode. SCTE should be selected if the modem is set for External Clock mode.

**NOTE: The SCT output cannot be returned on the SCTE leads to eliminate propagation delay problems with this interface.**



**Figure 3-11.**  
**BNC and Four**  
**TwinAx Connec-**  
**tors**  
**(BJ-77 Type)**

### 3.9.2 Model -TW8

The signaling used on this interface is Mil-Std 188-114C. Four TwinAx connectors (BJ-77 type) are used for the physical connection (see Figure 3-11).

A switch is provided to select whether the fourth TwinAx (SCT/SCTE) is to be used as an output (SCT) or as an input (SCTE). By setting the switch to the SCT position, the port becomes an output providing the clock to the connected device. When set for SCTE, the port becomes an input and will accept a clock from the connected device.

SCT should be selected if the modem is set for Internal or Slave Clock mode. SCTE should be selected if the modem is set for External Clock mode.

**NOTE: The SCT output cannot be returned on the SCTE leads to eliminate propagation delay problems with this interface.**

### 3.9.3 Model -T22

The signaling used on this interface is RS-422A. Five TwinAx connectors (BJ-77 type) are used for the physical connections (see Figure 3-12).

### 3.9.4 Model -T88

The signaling used on this interface is Mil-Std 188-114C. Five TwinAx connectors (BJ-77 type) are used for the physical connections (see Figure 3-12).

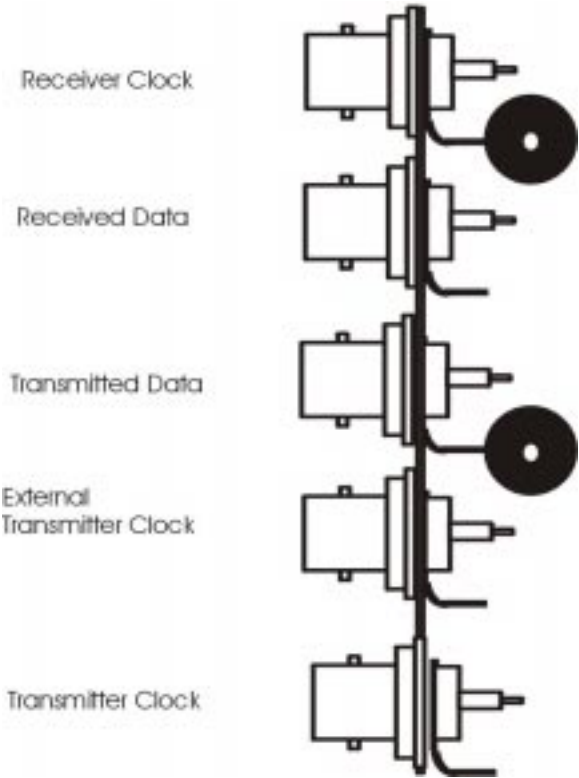
### 3.9.5 Model -D22

The signaling used on this interface is RS-422A. A standard 37-position, D-type female connector (DC-37) is used as the physical connections (refer to Table 3-N).

### 3.9.6 Model -D88

The signaling used on this interface is Mil-Std 188-114C. A standard 37-position, D-type female connector (DC-37) is used as the physical connections (refer to Table 3-N).

**Figure 3-12.**  
**Five TwinAx**  
**Connectors**  
**(BJ-77 Type)**



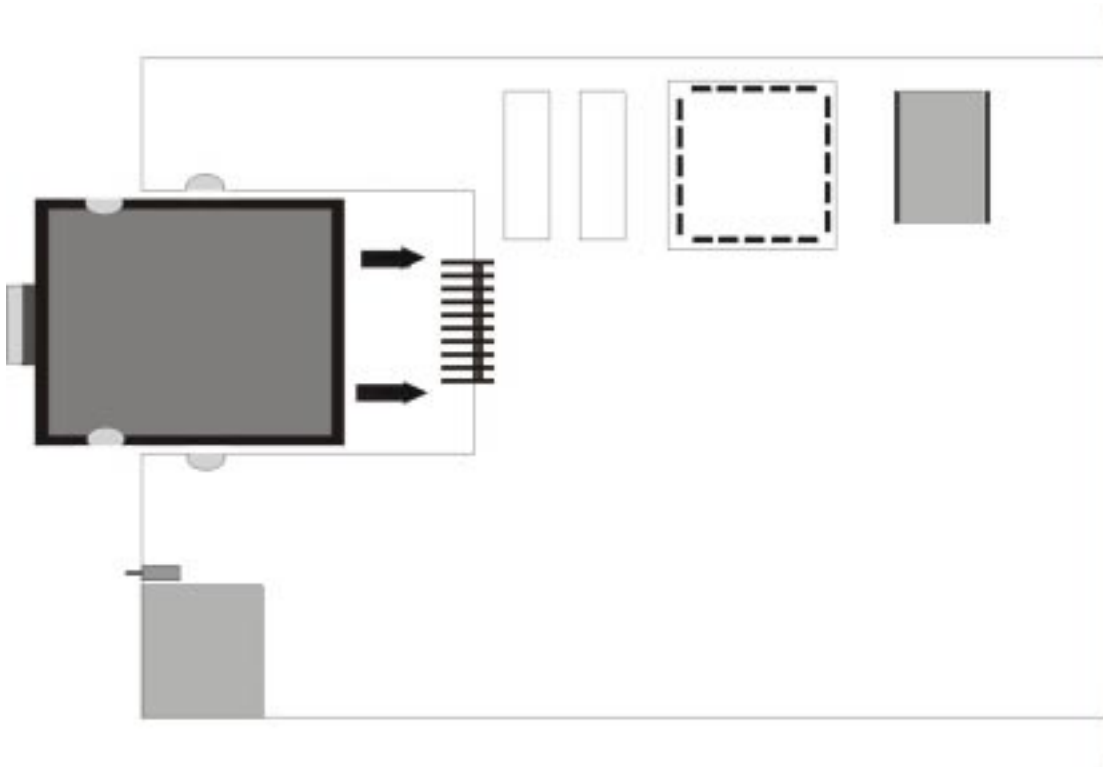
**Table 3-N. Models D22 and D88 Connector Pin Assignments**

SIGNAL	DC-37 PIN NUMBERS
SCR (A)	17
SCR (B)	35
RXD (A)	15
RXD (B)	33
TXD (A)	9
TXD (B)	27
SCTE (A)	5
SCTE (B)	23
SCT (A)	3
SCT (B)	21
SIGNAL GROUND	19
FRAME GROUND	1
*NOTE: These pin assignments do not correspond to RS-449	

### 3.10 Interface Reconfiguration

Figure 3-13 shows how the interface circuit board fits into the larger main modem board opening. A header-type connector is provided to connect the two circuit boards together. The interface board may be removed by loosening the two retaining screws and nuts, then pulling the board outward from its connector.

Once a replacement board is in position, the two flanged lock nuts and bolts are secured with built-in flat washers above and below the board junctures. It may be desirable to select a new data rate at this time using the front panel switch.



**Figure 3-13.**  
**Interface Card**  
**Installation**

### 3.11 Standalone Reconfiguration

To access the circuit board on a standalone unit, the enclosure cover must first be removed by loosening the six screws on the sides of the unit. Next, unplug the power supply connector from the PC board, and remove the two screws holding the rear panel in place.

The entire circuit board may now be removed by loosening the eight mounting screws. The interface board may now be changed as outlined in Section 3.10, "Interface Reconfiguration."

The rear panel supplied with the new interface must also be exchanged with the original rear panel. Simply slip the power cord strain relief grommet out of its mounting slot and fit it to the new rear panel. The unit may then be assembled in the reverse order of the disassembly.

## Chapter 4 - Modem Operation

### 4.1 Modem Operation

Though the actual electronic connection between the data equipment interface and a 2270 Modem differs from model to model, the electronic conversion from voltage level to optical level is similar in all applications. Figure 4-1 provides a functional block diagram of a typical 2270 Modem. (For simplicity, the test circuits are not shown.) The internal clock is shown with a broken line. The modem is shipped from the factory set to use the external clock. The optional clock may be selected via front panel switches at the time of installation.

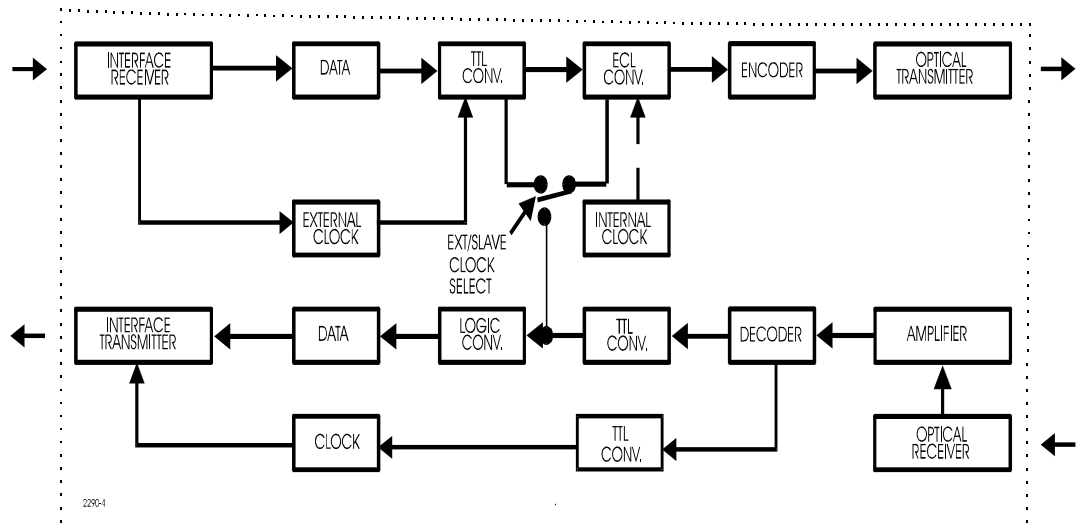
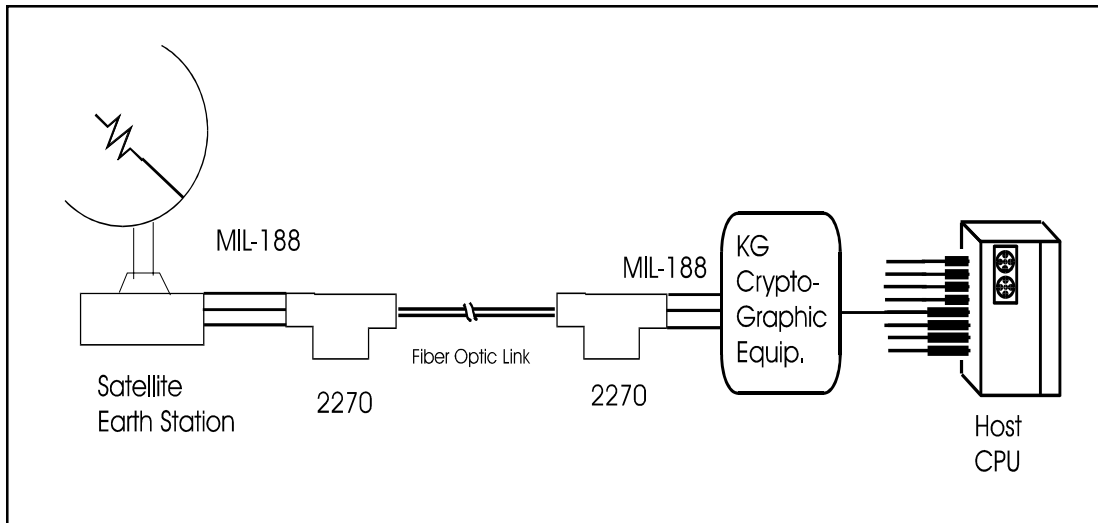


Figure 4-1.  
2270 Circuit  
Board Diagram

### 4.2 Fiber Optics

Since light is the transmission medium being used between modems, there are other advantages over conventional copper wire. In effect, most problems normally associated with large, multiconductor cables are eliminated. These include not only interface distance, but also grounding problems, Electromagnetic Interference (EMI), Radio Frequency Interference (RFI), and signal radiation. This latter factor is of particular importance where security of the system is important, and for compliance with FCC compatibility regulations.



**Figure 4-2.**  
**Typical High**  
**Speed 2270**  
**Modem**  
**Application**

### 4.3 Transmit Section

The data and clock signals input to the interface are converted to 5V logic signals for use by the modem circuit. These signals then pass through the loopback and test pattern selectors to be processed by the clock-correction circuit. Above 9 Mbps, the duty cycle of any transmit clock is corrected to approximately 50%.

The logic signals are then converted to the ECL signals used for modulation. This modulation uses a proprietary pulse width (PWM) encoding scheme. This signal drives the laser modulator to generate the optical signal for transmission over the fiber optic cable.

This optical signal, and the standard A-Lead interface voltage signals, can be seen in Figure 4-3. Note how the pulsed light transitions relate directly to the actual data being transmitted, and to the clock input from the modem.

The fast modulation used in the 2270 provides short 6-18 nanosecond pulses. These pulses are realized on every clock edge, and the pulse width is dependent on the actual data being transmitted. The time between these pulses is appropriate to the speed at which the data is being transmitted. Below 9 Mbps the pulse positions are also sensitive to the duty cycle of the transmit clock.

### 4.4 Receive Section

The duty cycle of the optical signal is close to 50% only at 20 Mbps. It reduces proportionally with the data rate such that it is only 0.0025% at 1 kbps.

A special optical receiver circuit converts the incoming signal to ECL level for demodulation. The clock is extracted by a very simple method which ensures a good Bit Count Integrity (BCI). The data is dependent on sampling the width of each pulse. These are converted to 5V logic levels which are passed through the loopback and test pattern detect circuits before connecting to the interface.

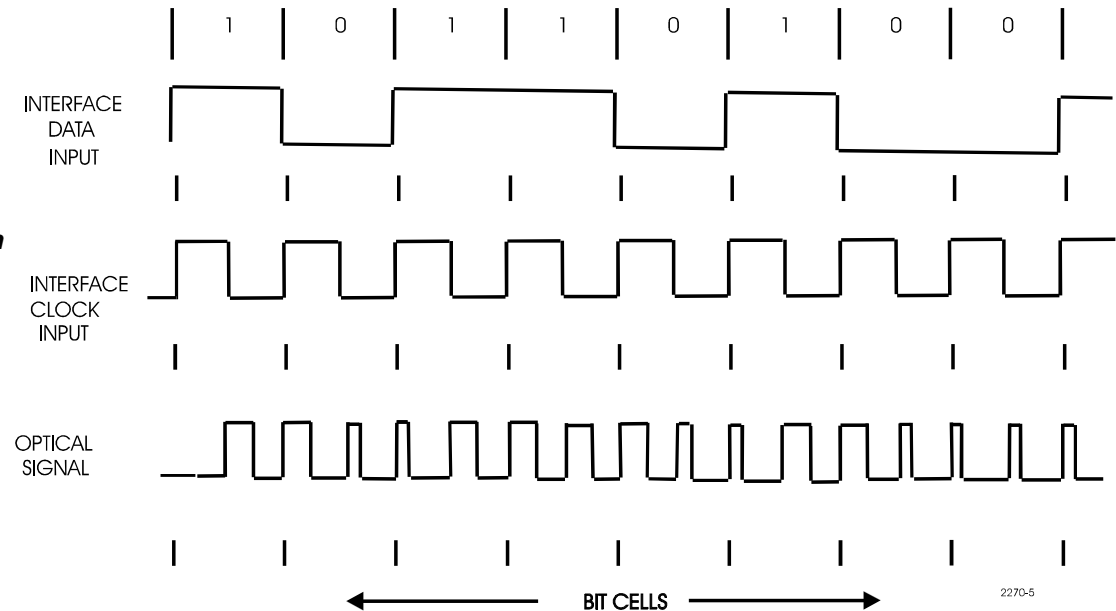
### 4.5 Full Rate Agility

The 2270 operates to full specifications over a range of rates from 1 kbps to 20 Mbps. Changing data rates does not require resetting switches or jumpers, except to set the clocking modes and the speed of the internal or self-test rate clock.



## 4.6 Bit Count Integrity

The 2270's design enables a much better integrity for the clock than the data. The data Bit Error Rate (BER) can be summarized as, "no more than one bit error in  $10^{11}$  bits." The Bit Count Integrity (BCI) can be summarized as, "no more than one count missed in 1400 hours."



**Figure 4-3.**  
**Data Organization**  
**with PWM Optics**

## 4.7 Duty Cycle Tolerance

The 2270 will accept any clock input duty cycle between 30% and 70%. Above data rates of 9 Mbps, any asymmetrical clock input is corrected to approximately 50% duty cycle. Below this rate, the duty cycle offset of the input is reproduced at the output. Below 6.5 Mbps, duty cycles from 25% to 75% can be tolerated.

The 2270 may cause the receive clock duty cycle to be inverted relative to the input clock, but the clock-to-data phasing will still be correct. This is an artifact of the design method used to ensure the high BCI.

The 2270's design stresses integrity of clock reproduction. This accounts for the exceedingly high BCI of less than one error in  $10^{14}$  clock cycles at 20 Mbps.

## 4.8 Control Signals

The 2270 interfaces support limited control signal functions. If Data Set Ready (DSR) is present as an interface output, it is asserted when the modem is powered and is not in any test or loopback mode. This standard DSR response functions as a Test Mode indication.

Some interfaces support both DSR and Test Mode (TM). A different DSR signal is made available to them. Its response complies with EIA and other standards by allowing only one condition for OFF — that is, only if the modem has received and responded to the command to turn on a remote loopback.

If Data Carrier Detect (DCD) is present as an interface output, it is asserted if the remote modem is sending valid optical carrier to the local modem. If the interface is looped back for testing, DCD is asserted — regardless of the state of optical carrier. However, when Flow Control Mode is active, the loopback forces DCD to follow the Request To Send (RTS) signal.

Clear To Send (CTS) is handled entirely by the interface card. Typically, CTS will follow the state of RTS with some delay between the time RTS turns on and CTS turns on. Some interfaces may interlock CTS with the presence of receive optical carrier through the DCD signal.

#### **4.8.1 Flow Control**

The only form of end-to-end flow control available will allow RTS at the near end to control DCD on the far end. This feature is enabled by the selection of Flow Control Mode. (Closing switch position 7 of the eight-section switch bank on the front panel selects Flow Control Mode.) Once enabled, this flow control will also stop any data transmission in the direction of the signaling if the RTS lead is in the “off state.” Even in loopback, the data will not flow unless RTS is asserted.

## Chapter 5 - Troubleshooting

### 5.1 Diagnostic Procedures

The following procedures are intended for use in the event of a system failure, not during the initial installation of a 2270 optical link. For initial installation checkout, refer to Chapters 1 and 2.

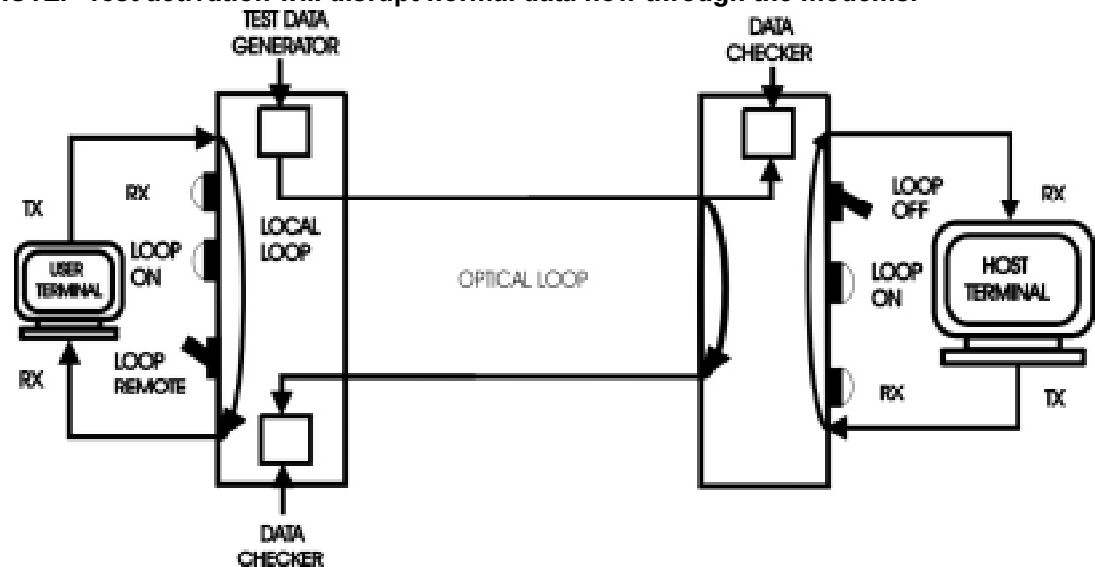
### 5.2 System Test

All 2270 Modems have built-in local loopback and system test features. These tests can be used to verify the basic operation of a 2270 system. See Figure 5-1 for an illustration of system test loopback.

**NOTE: Interface control of the loopback tests is only supported on the following modular interfaces: RS-423/RS-232C, RS-422, P53 and V.35.**

The test modes can be activated by setting the Loop switch on the front panel or by turning on the Local Loopback or Remote Loopback control leads in the electrical interface (supported interfaces only).

**NOTE: Test activation will disrupt normal data flow through the modems.**



*Figure 5-1.  
System Test  
Example From  
User-End  
of Fiber Link*

All of the test options are summarized in Table 5-A and described in detail in the following sections.

The ALT A and B option jumpers allow the user to select several different "Local" and "Remote" testing options. Front panel switch 8 (Alternate Loopback Functions) allows selection of various combinations of Local and Remote Test options.

**Table 5-A. Loopback Options**

Jumpers		Local Modem		Remote Modem	
Alt B	Alt A	Normal Mode *1	Alternate Mode *2	Normal Mode *1	Alternate Mode *2
OFF	OFF	Bi-Directional *3	Interface Only *4	Optical Only *5	Bi-Directional *6
OFF	ON	Interface Only *4	Bi-Directional *3	Optical Only *5	Bi-Directional *6
ON	OFF	Bi-Directional *3	Interface Only *4	Sys Test Only *7	Sys Test Only *7
ON	ON	Interface Only *4	Bi-Directional *3	Optical at Local End *8	Optical at Local End *8

This DIP sw is normally in the OPEN position. Ref. Pg 9

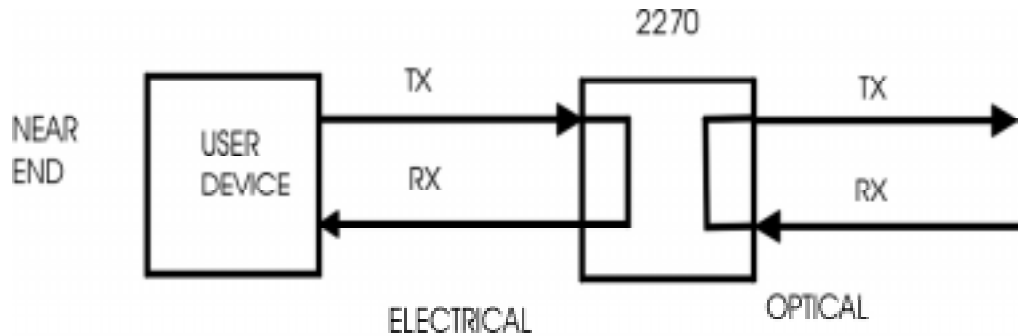
- \*1 Alternate Loopback Mode switch (Front Panel position 8) set to Normal (Open).
- \*2 Alternate Loopback Mode switch (Front Panel position 8) set to Alternate (Closed).
- \*3 Setting Loop switch on local modem to Loc causes local modem to enter loopback as in Figure 5-2.  
Local modem's Loop On indicator = ON.  
Setting Loop switch on local modem to OFF returns it to normal operation.
- \*4 Setting Loop switch on local modem to Loc causes local modem to enter loopback as in Figure 5-3.  
Local modem's Loop On indicator = ON.  
Setting Loop switch on local modem to OFF returns it to normal operation.
- \*5 *Step #1* Setting Loop switch on local modem to Rem causes modems to enter System Test Mode as in Figure 5-1.  
Local modem's Loop On indicator = ON, Data Rx = Blinking.  
Remote modem's Loop On indicator = ON, Data Rx = Blinking.  
*Step #2* Setting Loop switch on local modem to OFF causes the remote modem to enter loopback as in Figure 5-4.  
Local modem's Loop On indicator = ON.  
Remote modem's Loop On indicator = Blinking.  
*Step #3* Setting Loop switch on local modem to Rem causes both interfaces to loopback.  
Local modem's Loop On indicator = Blinking.  
Remote modem's Data Rx = Blinking.  
*Step #4* Setting Loop switch on local modem to OFF returns it to normal operation.
- \*6 *Step #1* Setting Loop switch on local modem to Rem causes the modems to enter System Test Mode as in Figure 5-1.  
Local modem's Loop On indicator = ON, Data Rx = Blinking.  
Remote modem's Loop On indicator = ON, Data Rx = Blinking.  
*Step #2* Setting Loop switch on local modem to OFF causes remote modem to enter loopback as in Figure 5-5.  
Local modem's Loop On indicator = ON.  
Remote modem's Loop On indicator = Blinking.  
*Step #3* Setting Loop switch on local modem to Rem causes both interfaces to loopback.  
Local modem's Loop On indicator = Blinking.  
Remote modem's Data Rx indicator = Blinking.  
*Step #4* Setting Loop switch on local modem to OFF returns it to normal operation.
- \*7 *Step #1* Setting Loop switch on local modem to Rem causes modems to enter System Test Mode as in Figure 5-1.  
Local modem's Loop On indicator = ON, Data Rx = Blinking.  
Remote modem's Loop On indicator = ON, Data Rx = Blinking.  
*Step #2* Setting Loop switch on local modem to OFF returns it to normal operation.
- \*8 *Step #1* Setting Loop switch on local modem to Rem causes the local modem to enter loopback as in Figure 5-6.  
*Step #2* Setting Loop switch on local modem to OFF returns it to normal operation.

### 5.2.1 Local Loopback Test

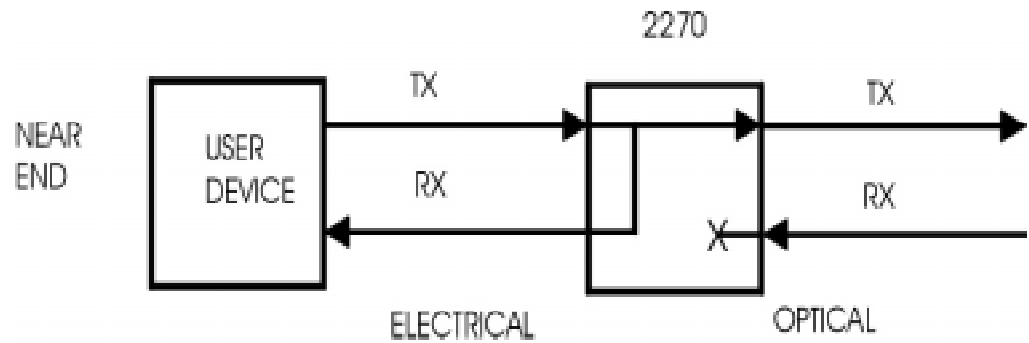
When activated, the local loopback test will cause all data transmission from the near-end (local) user device to be looped back toward the receive of that same device. No data is looped back to the far-end (remote) user device unless a bidirectional Local Loopback method is selected (refer to Table 5-A, "Loopback Options").

The loopback point is set at the electrical interface of the local modem (see Figures 5-2 and 5-3). Refer to Chapter 3, "Data Interfaces," for pin numbers.

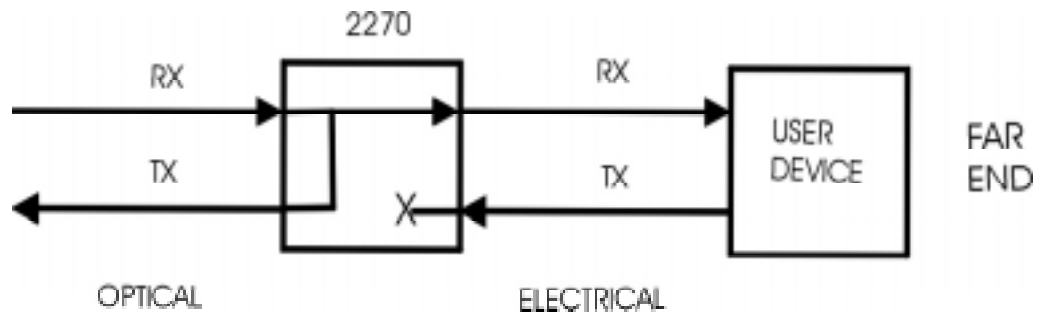
**Figure 5-2.**  
"Bi-Directional"  
Local Loopback  
Active



**Figure 5-3.**  
"Interface Only"  
Local Loopback  
Active



**Figure 5-4.**  
"Optical Only"  
Remote Loopback  
Active



### 5.2.2 Remote Loopback Test

To activate the Remote Loopback Test, set the Loop switch to REM and, after the Rx Data Indicator begins to flash, set the switch back to OFF. For the “System Test Only” option, retain the test switch in the REM position (refer to Section 5.2.3). The Local Loop On indicator will remain on, indicating that the Remote Loopback has latched to the active state in the far-end modem.

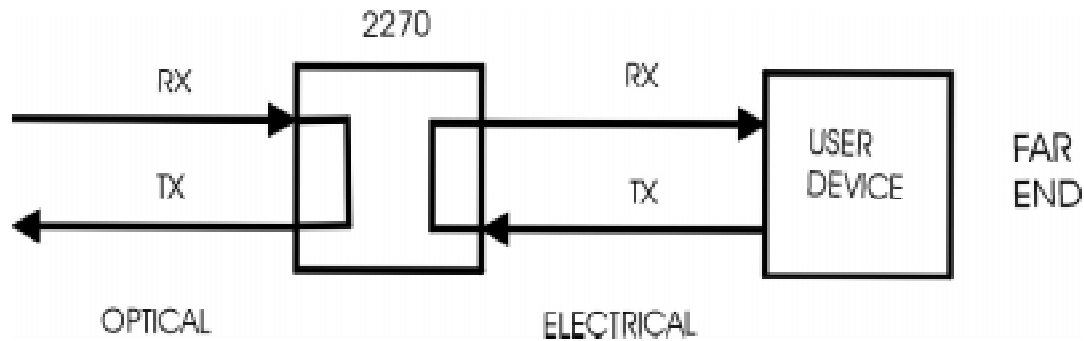
The Loop On Indicator at the far-end modem will flash to indicate that a remote loopback is active at that end.

To release the Remote Loopback Test, set the Loop switch to REM and, after the Loop On indicator begins to flash, set the switch back to OFF.

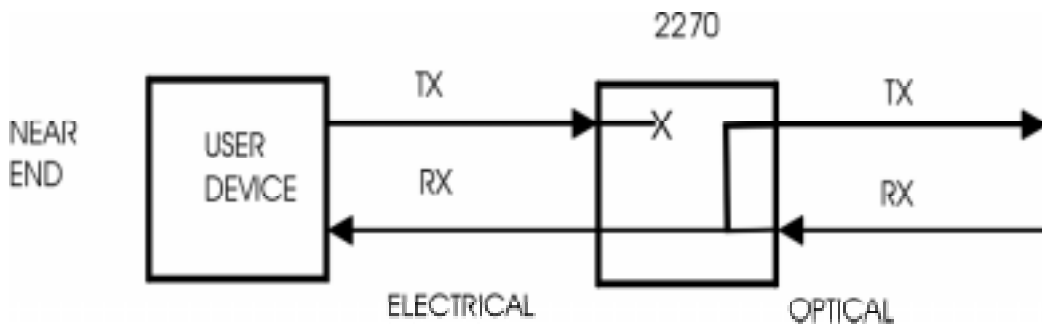
A Remote Loopback can also be activated through the electrical interface if it supports the Remote Loopback control lead (refer to Section 3, “Data Interfaces,” for pin numbers). This lead must be driven to the ACTIVE (positive voltage) state and released after an appropriate delay period.

Table 5-A defines the types of Remote loopbacks that are possible with each configuration of the ALT A and B jumpers. Figures 5-1, 5-4, 5-5 and 5-6 illustrate the “System Test Only,” “Optical Only,” “Bi-Directional” and “Optical at Local End” forms of remote tests.

**NOTE: If any modem locks up where the Loop On indicator stays ON, it will require unplugging the modem and reinserting it, or recycling the power off and on to reset the modem.**



*Figure 5-5. “Bi-Directional” Remote Loopback Active*



*Figure 5-6. “Optical at Local End” Loopback Active*

### 5.2.3 System Loopback Test

This section describes the “System Test” Remote Loopback test feature in detail. See Figure 5-1 for an illustration of System Test.

The System Test provides a simple way to verify most of the components in a 2270 link without any special test equipment:

1. Both optical transmitters
2. Both optical receivers
3. Both transmit and receive optical fibers
4. The far-end electrical interface and user device (via the far-end local loopback)
5. The near-end electrical interface and user device (via the near-end local loopback)

Three loopback points are set in the system during the System Loopback test. One is set at the far-end modem electrical interface, another at the far-end modem optical interface and another at the near-end electrical interface (see Figure 5-1).

To activate the System Loopback test, set the Loop switch to REM or drive the electrical interface Remote Loopback control lead in the electrical interface to the ACTIVE (positive voltage ) state. Refer to Section 3, “Data Interfaces,” for pin numbers.

When activated, the near-end modem will begin transmitting a test pattern to the far-end modem and the Loop On indicator will light.

When the far-end modem detects the test pattern presence, the Loop On indicator will light and the Rx Data indicator will blink. This means that the test pattern was properly received and that the System Test optical loopback has activated.

The far-end modem will then return the test pattern back to the near-end modem. Also, all data transmission from the far-end user device will be looped back toward the receive of that same device.

When the near-end modem detects the presence of the returned test pattern, the Rx Data indicator will blink. This indicates that the test pattern was properly received at both ends of the link.

**NOTE: When a System Test is successful, both Rx indicators should be blinking approximately twice per second and both Loop On indicators should be solidly lit.**

If the Rx indicators do not blink at a steady rate, or if the Loop On indicators do not solidly light, the System Test is failing (or intermittent) and the link requires repair.

The data rate of the System Test pattern generator is set by selecting the internal clock rate as given in Table 2-B.

**NOTE: The pattern used is a  $2^{20}$ -1 pseudorandom pattern. Do not use this pattern for checking through the interfaces unless the data checker is disabled by the TST OFF jumper or by selecting a remote test option from Table 5-A which excludes the “System Test” feature.**

## Chapter 6 - Diagnostic Procedures

---

### 6.1 2270/2201 Diagnostic Procedures

The following diagnostic procedures should be followed to test the 2270 system, troubleshoot a defective link or detect a defective fiber optic cable, connector, modem or power supply.

**NOTE: Refer to the 2201 Rack Chassis / 2200R Redundant Modem Card User Manual for diagnostic procedures for the 2201 Rack Chassis and power supplies.**

#### Required Equipment

- 1) Multimeter - for AC voltage, resistance and continuity tests
- 2) Fiber Optic Power Meter - should be calibrated at the correct optical wave length (1300 nm) with the appropriate optical connectors
- 3) A short (one meter or less) 62.5  $\mu$ M fiber optic jumper cable, terminated with the appropriate connectors
- 4) A Bit Error Rate Tester (BERT) with the appropriate electrical interface and cable

Step	Symptom	Possible Cause(s)	Action
1	No power indicator on front panel(s);	No AC power	Check AC power source
2	No power indicator on front panel(s);	Defective modem	Replace Modem

**NOTE: Once any power system problems have been corrected, continue the system checkout after the System Test Diagnostic Procedure.**

### 6.2 System Test Diagnostic Procedure

Step	Symptom	Possible Cause(s)	Action
1	No data transmission between modems	Defective fiber optic modem(s), cable(s) or connectors	Set the System Loopback switch on one modem. Verify the proper operation of the test (refer to Chapter 5). If the test is successful, proceed to Step 5. If the test fails, continue to the next step.
2	Verify the optical cable loss. Remove the Tx fiber from the modem. Use the optical power meter and fiber optic jumper cable to determine the optical launch power for this modem. Reconnect the Tx fiber to the modem. Remove the Rx fiber from the modem and determine the optical receive power into this modem. Reconnect the Rx fiber to the modem. Repeat these steps for the modem at the other end and record both optical power levels.		

**NOTE: Optical power readings are dependent on data rate. To make accurate optical power measurements, use a 20 Mbps data rate. If the modem is normally operating at a rate other than 20 Mbps, use the internal clock mode to obtain the maximum operating speed (refer to Section 2.7.2). The standard Internal Clock Oscillator (-08) with a rate switch setting of CCC results in an operating speed of 20 Mbps. Use this mode and speed for making optical power measurements.**



Step	Symptom	Possible Cause(s)	Action
2 (cont.)	<p>Perform the following optical loss calculation:</p> <ul style="list-style-type: none"> <li>Local Receiver level minus remote Transmit level = near-end link loss figure</li> <li>Remote Receive level minus local Transmit level = far-end link loss figure</li> </ul> <p>Check the optical cable loss figure against the optical link loss budget specified in Table 1-B for the specific fiber-optic modem. For the HP Laser version, check that the Tx PWR and Rs SENS switches are set according to Section 1.10.3.</p> <p>If the actual cable loss still exceeds the loss budget for the modem, go to Step 3. If the cable loss is within the specified loss budget for the modem, go to Step 5.</p> <p><b>NOTE: The link loss should be at least 3 dB lower than the loss budget specified for the modem. This design margin will compensate for LED/Laser aging and small changes in the actual link loss.</b></p>		
3	Cable loss exceeds modem loss budget	Defective F/O cable	Repolish or replace defective connectors
4	Cable loss exceeds modem loss budget	Defective F/O connectors	Repair or replace defective cable
5	Set up BERT for the proper clocking, data rate and format as used with the circuit. Use the existing interface cables if possible. Connect the BERT in place of the local user device. Connect a data clock loopback connector in place of the remote user device. Run the BERT test and go to the next step.		
6	System loopback test passes but modems will not pass data	Modem not configured properly	Verify/correct switch and strap settings on modem and devices
7	System loopback test passes but modems will not pass data	Interface cables damage or miswired	Repair damaged or miswired cables
	Optically loopback each modem and repeat BERT test as detailed in Step 5		
8	Modem fails BERT test when optically looped back to itself	Defective modem or electrical interface	Replace defective modem

## Chapter 7 - Specifications

---

### 7.1 Diagnostic Indicators and Controls

System Test, Optical Power, Rx/Tx, Power On, Power Alarms (2201)

### 7.2 Optical Interface

Composite Error Rate	1 in 10 <sup>10</sup> or better
Fiber Optic Cable Compatibility	50 to 62.5 micron multimode or 8 to 10 micron single mode fiber
Transmitter Type	LED (850 nm) Laser diode (1310 nm)
HI/LO Optical Power Switch (HP Laser Model Only)	Reduces Peak Modulation Intensity by at least 3 dB
Wavelength	850 nm (LED Model) 1310 nm (Laser Models)
Fiber Optic Connectors	ST or FC type
Fiber Optic Receiver	PIN diode
Transmission Code	Pulse Width Coding
Fiber Optic Transmission Specifications <i>(All powers are measured at 20 Mbps unless noted)</i>	
Optical Launch Power	<u>High Power (HP) Laser</u> > -6 dBm HI Tx (at 20 Mbps) -11 to -8 dBm LO Tx (at 20 Mbps)  <u>Low Power (LP) Laser</u> > -8 dBm (at 20 Mbps)  <u>850 LED</u> > -14 dBm (at 20 Mbps)
Fiber Optic Link Loss Budget	
850 nm LED	>6 dB (62.5/125 MM fiber)
1310 nm HP Laser	>15 dB (SM or MM fiber)
1310 nm LP Laser	>10 dB (SM or MM fiber)

## 7.3 System Electrical

Interfaces Supported	RS-232C/RS-423, RS-422, V.35, DS1/T1, TTL/BNC, Programmable Buffered RS-530, Mil Std-188-114C, RS-530, Transparent T1/E1
Duty Cycle for Clock Input	50% $\pm$ 20% 6.5 Mbps to 20 Mbps 50% $\pm$ 25% less than 6.5 Mbps
Interface Type	Interface Connector
RS-232C/423, Programmable RS-530, RS-530	female DB-25
RS-422/Mil Std-188-114C	female DC-37
CCITT V.35	female 34-pin Winchester
DS1/T1, B2	four-position barrier strip
TTL/BNC	four male BNC coaxial connectors
RS-422/Mil Std 188-114C	four or five male twinaxial connectors (BJ-74)
B1	female DA-15
B3	two male BNC connectors
Power Requirement	
Standalone	
Standard	115 VAC $\pm$ 10% @ 0.22 Amps (max.)
Optional	230 VAC @ 0.11 Amps optional (max.)
	47 to 63 Hz (both)
Optional	48 VDC (nom) @ .5 Amps

## 7.4 Physical Dimensions

Standalone	8.50 W x 12.8 D x 2.5 H inches
2201 Rack Chassis	19.0 W x 8.75 D x 12.0 H inches
2202 Modem Shelf	19.0 W x 12.75 D x 3.5 H inches
Rack-Mount PC Card	7.8 W x 12.50 D x 1.0 H inches
Unit Weights (shipping)	
2270 Standalone	3.63 pounds
2200R Main PC Card	0.75 pounds without interface
2201 Power Supply Monitor Card	0.50 pounds
2201 AC Power Supply	9.0 pounds each
2201 DC Power Supply	3.0 pounds each
2201 Rack Chassis	7.70 pounds
2202 Modem Shelf	3.0 pounds
2200-I Interface PC Card	0.16 pounds

Operating Environment

Temperature  
Humidity

0 to 50°C  
0 to 95% (non-condensing)

MTBF

62,500 hours (calculated)

## 7.5 2270 Fiber Optic Modem Configurations

2270-S-XXX-XX-XX-X  
2270-R-XXX-XX-XX-0

S = STANDALONE  
R = RACK-MOUNT

\* POWER OPTIONS  
0- N/A  
1- 115 VAC  
2- 115/230 VAC IN-LINE  
3- -48 VDC

\* CRYSTAL OPTIONS  
00- NO CRYSTAL  
01- 21.504M  
02- 24.704M  
03- 16.384M  
04- 25.248M  
05- 13.824M  
06- 921.6K  
07- 7.373M  
08- 40.00M (DEFAULT CRYSTAL)  
09- 12.928M  
10- 6.144M  
11- 25.856M  
12- 230.4K  
13- 24.576M

\* FIBER OPTIONS  
MULTIMODE  
01- 850 nm ST/FC  
11- 1310 nm ST  
13- 1310 nm FC  
SINGLE MODE  
11- 1310 nm ST  
13- 1310 nm FC

\*INTERFACE OPTIONS  
-22 RS-422/RTS LOW/DC37  
-32 RS-232/DB25  
-35 V.35/MRC34  
-D22 HIGH-SPEED (20Mb) RS422/DC37  
-D88 MIL 188-114/DC37  
-H22 RS-422/RTS HI/DC37  
-ECL PROGRAMMABLE BUFFERED ECL; HSSI COMPATIBLE TO 20 Mbps; DB25  
\*\* -L25 LARGE PROGRAMMABLE 256-BIT BUFFER; (EXTERNAL CLOCK) RS422; DB25  
\*\* -LB1 LARGE PROGRAMMABLE 256-BIT BUFFER; (INTERNAL CLOCK) RS422; DB25  
\*\* -LB4 LARGE PROGRAMMABLE 256-BIT BUFFER; (STATION CLOCK) RS422; DB25  
\*\* -P53 PROGRAMMABLE 8-BIT BUFFER; (EXTERNAL CLOCK) RS422; DB25  
-R2R RS-422/BAL CTS/DC37  
-R30 RS-530/DB25  
-RPB REDUNDANT PADDLE BOARD (RACK MOUNT ONLY)  
-TW 422/TWINAX  
-TW8 MIL 188-114/TWINAX  
-T22 422/5 CONN TWINAX  
-T88 MIL 188-114/5 CONN TWINAX  
000 NO INTERFACE

\*\* CONSULT FACTORY TO CONFIRM CONFIGURATION

## Appendix A

---

### A.1 Customer Service Department Repair Warranty

Repairs performed by the Canoga Perkins Customer Service Department are warranted to be free from defects in material and workmanship for a period of 90 DAYS from the date of shipment of the repaired product, or until the expiration of the original factory warranty, whichever is longer.

Shipping charges to and from Canoga Perkins will be at the customer's expense. Units will be shipped F.O.B. Origin. Repaired units will be returned to the customer by standard ground shipment unless otherwise specified, with any additional costs for customer specified overnight or second day deliveries at the customer's expense.

### A.2 Return Policy

#### RETURN MATERIAL AUTHORIZATION (RMA)

You must obtain an RMA number from the Customer Service Department, (818) 718-6300, before you return a Canoga Perkins product for service or repair.

If the product's warranty has expired, you will need to provide the Canoga Perkins Customer Service representative with a purchase order number to authorize the repair.

Products should be returned with the original shipping carton/packing, whenever possible. A description of operation failure and results of any diagnostic tests should be included.

### A.3 Advance Replacement Policy

Canoga Perkins will ship a replacement unit for most standard products, overnight delivery, anywhere in the US for a flat rate. Please call the Customer Service Department at (818) 718-6300 for a current list of product repair charges.

All returned equipment, with RMA number, should be sent to:

**CANOGA PERKINS CORPORATION**  
**Customer Service Department**  
20600 Prairie Street  
Chatsworth, California 91311-6008  
Business (818) 718-6300  
(Monday through Friday  
7 a.m. - 3:30 p.m. Pacific Time)  
FAX (818) 718-6312 (24 hrs.)

**24 Hour Emergency Repair Hot Line**  
**(800) 360-6642**

## A.4 Warranty

### Electronic Products

Canoga Perkins warrants to the Customer that all goods sold to the Buyer will perform in accordance with the applicable data sheets, drawings or written specifications, and at the time of sale will be free of defects in material and workmanship. **The warranty period for the WA-4 and WA-8 Wave Division Multiplexing Products and OSP test equipment will be ONE (1) year from the date of shipment. The warranty period for all other data communications equipment will be THREE (3) YEARS from the date of shipment.** This warranty will apply unless goods have been subject to lightning damage or other Acts of Nature, misuse, neglect, accident, damage, improper installation or maintenance, or alteration or repair by anyone other than Seller or its authorized representative. Buyer should notify Canoga Perkins promptly in writing of any claim based on warranty, and Canoga Perkins, at its option, may first inspect such goods at the premises of Buyer, or may give written authorization to Buyer to return the goods to Canoga Perkins, transportation charges prepaid, for examination by Canoga Perkins. Canoga Perkins will not be liable for any inspection, packing or labor costs in connection with return of goods. In the event that Canoga Perkins breaches its obligation of warranty, the sole and exclusive remedy of Buyer is limited to replacement, repair or credit of the purchase price, at Canoga Perkins' option.

### Cable Products

Carefully inspect the cable upon receipt. If the cable is defective, contact the Canoga Perkins Customer Service Department within ten (10) working days of receipt to obtain a Return Material Authorization (RMA) number before reshipping to Canoga Perkins. If defective, the cable will be repaired or replaced in accordance with the warranty of the cable manufacturer, which is the sole warranty. Unless the customer order specifies that Canoga Perkins shall install or supervise installation of the cable, Canoga Perkins assumes no responsibility for the installation. Canoga Perkins shall not be liable for defective cable, cost of removing defective cable, or cost of installing replacement cable.

### Limitations

OTHER THAN THOSE EXPRESSLY STATED HEREIN, THERE ARE NO OTHER WARRANTIES OF ANY KIND, EXPRESS OR IMPLIED, AND SPECIFICALLY EXCLUDED BUT NOT BY WAY OF LIMITATION, ARE THE IMPLIED WARRANTIES OF FITNESS FOR A PARTICULAR PURPOSE AND MERCHANTABILITY. IT IS UNDERSTOOD AND AGREED THE SELLER'S LIABILITY WHETHER IN CONTRACT, IN TORT, UNDER ANY WARRANTY, IN NEGLIGENCE OR OTHERWISE SHALL NOT EXCEED THE AMOUNT OF THE PURCHASE PRICE PAID BY THE PURCHASER AND UNDER NO CIRCUMSTANCES SHALL SELLER BE LIABLE FOR SPECIAL, INDIRECT, INCIDENTAL OR CONSEQUENTIAL DAMAGES. THE PRICE STATED FOR THE EQUIPMENT IS A CONSIDERATION IN LIMITING SELLER'S LIABILITY. NO ACTION, REGARDLESS OF FORM, ARISING OUT OF THE TRANSACTIONS OF THIS AGREEMENT MAY BE BROUGHT BY PURCHASER MORE THAN ONE YEAR AFTER THE CAUSE OF ACTION HAS ACCRUED. SELLER'S MAXIMUM LIABILITY SHALL NOT EXCEED AND BUYER'S REMEDY IS LIMITED TO EITHER (i) REPAIR OR REPLACEMENT OF THE DEFECTIVE PART OF PRODUCT, OR AT SELLER'S OPTION (ii) RETURN OF THE PRODUCT AND REFUND OF THE PURCHASE PRICE, AND SUCH REMEDY SHALL BE BUYER'S ENTIRE AND EXCLUSIVE REMEDY.